



(No Model.)

2 Sheets—Sheet 1.

N. TESLA.
ELECTRIC GENERATOR.

No. 611,916.

Patented Jan. 2, 1894.

**ANNIVERSARY EDITION
REVISED 25-MAR-2015**

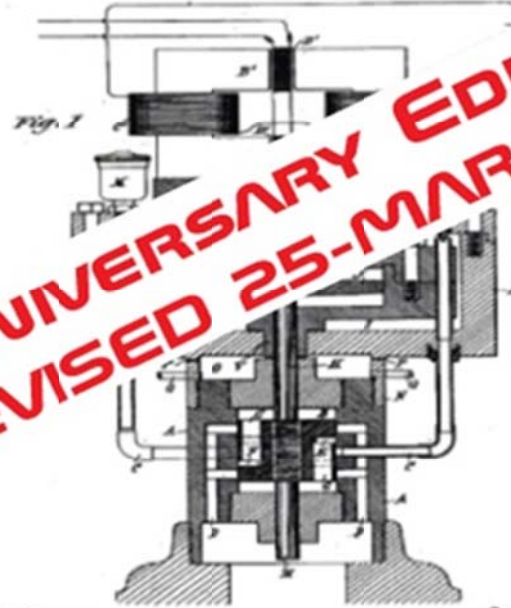

Witnessed
R. T. Gaylord

Inventor
Nikola Tesla
By Geo. C. Shreve
Duncan & Brown

Nikola Tesla

The Quantum Energy Generator system (QEG) is an adaptation of one of Nikola Tesla's many patented electrical generator / dynamo / alternator designs. The particular patent referenced is No. 511,916, titled simply "Electric Generator", and dated January 2, 1894 (see back of this manual). The adaptation is a conversion from a linear generating system with a reciprocating rod whose period is electrically regulated, to a rotary generating system. The reciprocating rod is replaced by a rotor whose motion is also electrically regulated, by means of tuned parametric resonance (parametric oscillation). The original intent of the patent (electrical regulation of the period (frequency) of a repetitive mechanical motion) is further expanded through subsequent utilization and application of mechanical self-resonance and radiant energy, in order to make the machine self-sustaining.

The QEG prototype is scaled to produce electrical power in the range of 10-15 kW (kilowatts) continuously, and can be set up to provide either 120 Volt or 230-240 Volt single phase output. We are also planning future designs to provide 3-phase power.

Service life of the device is limited only by certain replaceable components, such as bearings, v-belts, and capacitors. The basic machine should operate trouble-free (with minimal maintenance) for as long as any good quality electro-mechanical appliance, such as a quality washing machine or refrigerator. Heavy-duty mechanical components are used throughout for reliability.

The QEG is not a complicated device, as it is designed (like Tesla's other 'discoveries') to work in harmony with nature's laws, rather than the power wasting closed-system symmetric motor and generator designs used in today's mainstream industry.

An effective way to understand the operating principle of the QEG is to think of it as a self-powered toroidal transformer with high-voltage primary, and low voltage secondary. The primary high voltage is self-generated through mechanically pumped parametric resonance. The resonance occurs as a function of the spinning rotor modulating the reluctance/inductance in the primary tank circuit windings. This modulation initiates an oscillation which can develop up to 20,000 volts (20kV) or more in amplitude, with frequency determined by the tank capacitor value and inductance value in the primary windings. Power is then transferred to the secondary during the intervals where the rotor is between pole pieces (unaligned). The resultant power output is relatively high-voltage, low current AC (up to 5kV or more, at up to 2 Amps or more). In today's alternative energy terminology, it would be called a type of resonance machine.

The circuitry that develops high power in this device is based on an existing but under-utilized power oscillator configuration, however, the 'quantum' part of the design has to do with how the basic generator output is enhanced by the core mechanical resonance, and insertion of radiant energy to produce additional power. Conventional alternators (AC generators) consume much more input power than the output power they provide. For example, one brand of power take off (PTO) alternator uses 18,000 watts (24 horsepower) to develop 13,000 watts of output power. In the QEG, input power is used only to maintain resonance in the core, which uses a fraction of the output power (under 1000 watts to produce 10,000 watts), and once development is completed, the QEG will provide this power to its own 1 horsepower motor. This is known as over-unity, or COP over 1 (Coefficient of Performance). Once the machine is up and running at the resonant frequency, it will power itself (self-sustaining).

James M. Robitaille

NOTICE

TO BE READ AND UNDERSTOOD BY ALL QEG PROJECT CREWS

Fix the World (FTW) is not responsible for the actions of others. We can only tell you our experience. We have discovered it is essential that those wishing to build a QEG use careful thinking, patience, and consideration for the greater good.

The inhabitants of planet Earth are entering into a new paradigm and a new way of doing business. In honor of Nikola Tesla, the QEG is a gift freely given to the world, and FTW's involvement is strictly altruistic.

The QEG is an electromechanical device and as such, safety for the individual and end user should always be of prime concern. It is therefore essential that persons assembling the device are experienced in the field of electro-mechanical assembly. Some level of familiarity with quantum physics would also be very helpful.

IF YOU ARE TRAINED IN TRADITIONAL PHYSICS, AND HAVE NOT BEEN EXPOSED TO ANY QUANTUM ENERGY RESEARCH OR DESIGNS, WE RECOMMEND THAT YOU FIRST BECOME FAMILIAR WITH SOME BASIC QUANTUM ENERGY DEVICES AND HOW THEY WORK (e.g. electrical and mechanical resonance, tuning, and radiant energy).

QEG Cautions-Hazards

Electrical / Mechanical devices are inherently dangerous. Electrical shock can cause burns, serious injury and in some cases death. Mechanical hazards can result in dismemberment and in some cases death.

Due diligence has been applied to ensure that the QEG instructions are complete and correct. All local and country-specific electrical and mechanical code implications, by which a QEG might be installed and operated, cannot possibly be known by us. Nor is it conceivable that any and all possible hazards and/or results of each procedure or method have been accounted for.

It is for these reasons that the QEG must be either directly installed or supervised by an experienced electrician or electrical technician/engineer, to ensure the installation is done safely and in accordance with local electrical code. However, the QEG is installed the same way as any commercial generator and does not violate any electrical codes. Anyone who uses the QEG installation instructions (including but not limited to any procedure or method of installation) must first satisfy themselves that neither their safety, nor the safety of the end user, will be endangered over the course of the installation and operation of the QEG.

It is imperative to understand you need PROFESSIONAL and EXPERT ADVICE to install a QEG.

HAZARDOUS VOLTAGE AND CURRENT LEVELS ARE PRESENT IN THE QEG CORE AND ASSOCIATED CIRCUITRY WHEN OPERATING! PLEASE USE CAUTION!

MAINTAIN SAFE DISTANCE, AND DO NOT TOUCH ANY CONNECTIONS TO THE CORE, OR MAKE ANY ELECTRICAL ADJUSTMENTS WHILE THE MACHINE IS RUNNING!

Always stop the machine when making connections or adjustments. The tank circuit capacitors do not normally hold a charge when the machine is stopped, but for added assurance, it is a good idea to try to discharge them before handling.

To Discharge Capacitors: PROVIDED THE MACHINE HAS STOPPED, momentarily short out the two primary coil leads (connected to the capacitor bank) with a 100 - 1000Ω, 5 – 10W resistor. If no resistor is on hand, simply lay a screwdriver across the coil leads momentarily.

The instructions in this build manual are designed to show how we have found the building of the device to be accomplished, and any negative outcomes that result are completely the responsibility of the person/company building it; FTW provides no guarantee for the successful completion of the QEG.

This notice serves the purpose of communicating the serious nature of building a quantum machine, as we are well aware that there have been severe restrictive agencies involved with their suppression. Quantum free energy isn't taught at University and most designers have heretofore been unsuccessful at mass distribution. It is YOUR RESPONSIBILITY therefore to make certain you are building the QEG with positive intentions for humanity, and lashing out legally or otherwise to FTW, HopeGirl and/or the designer and his family, is a violation of goodwill and will in no way be attended to. We know of no other way to do this but to go back to the "HONOR SYSTEM."

In reading this notice I agree that:

- 1) I WILL NOT ATTEMPT TO BUILD A QEG UNLESS I DO SO APPROPRIATELY WITH AN ELECTROMECHANICAL ENGINEERING PROFESSIONAL.
- 2) I WILL NOT COMMISSION (TURN ON) OR INSTALL THE QEG WITHOUT AN ELECTROMECHANICAL ENGINEERING PROFESSIONAL.
- 3) UNDER THE ABOVE CONDITIONS, I MAY USE THE QEG ASSEMBLY INSTRUCTIONS FOR PERSONAL USE, AND UNDERSTAND THE NEED FOR IMPECCABLE COMMITMENT TO THE BETTERMENT OF HUMANITY. IN THE BEST INTEREST OF THE PEOPLE OF PLANET EARTH, I WILL NOT ATTEMPT TO MISUSE OR MONOPOLIZE THE QEG ASSEMBLY INSTRUCTIONS IN ANY CAPACITY, NOR WILL I ATTEMPT TO MAKE A HUGE PROFIT AT THE EXPENSE OF ANOTHER HUMAN BEING.

IMPORTANT – Please make certain that persons who are to use this equipment thoroughly read and understand these instructions and any additional instructions prior to construction, installation and operation.

Dear Builder,

It is no easy task to build the QEG, and we want to encourage you by offering a short treatise on the importance of ‘consciousness’ in this endeavor. Many are becoming more familiar with Nikola Tesla, his desire for all people to have access to free energy, and his failed attempt to expose this technology to the world. Many have followed him with the same aspirations and, similar to Tesla’s plight, have also been prevented by powers beyond their control. The “free” energy movement is rife with horror stories ranging from government theft of patents, to reputations destroyed, to the murder of a number of brilliant scientists/inventors.

We must all consciously and constantly rise above these tyrannical infringements, and create an environment for ourselves and our neighbors, and rediscover Nature’s Laws to be able to live and thrive. We must leave off responding in incredulity to what was “done to us” when we were told and believed we couldn’t create free energy. We are now awake to the point that we know they were lying. Who are they? The elite for starters – follow the money (watch [THRIVE](#)); J.P. Morgan couldn’t put a meter on an energy plan for the world, and so destroyed any chance of that happening through several vicious attacks on Tesla’s reputation and livelihood – basically got Tesla’s ideas out of the way for his own profit and power – and maliciously destroyed the man (youtube: [Tesla’s Autobiography](#)). While the electric companies have told the people theirs is the only way to get electricity, and we are dependent on them, the truth is that we have been deprived of this alternative (quantum) energy source for close to 130 years. Morgan’s grip on the energy supply has not loosened one bit in all that time. In fact, you are probably paying more for electricity than ever before, all things being equal.

So how do we affect our future now, and free ourselves and the generations to come after us completely from energy tyranny? Building the QEG is one way. It is a journey that requires you to think deeply about processes that will, in turn, expand your senses to enable you to receive information from the quantum field of consciousness, or God if you prefer this reference. We believe we had Divine inspiration and help, which began with a burning desire to “get off the grid” and also do something significant for humanity. The timing is wonderful because, as of the writing of this, the entire planet is in turmoil as never before, and people will need to not only be self-sufficient, we will all need to live according to what is good for all (Ubuntu), and help each other for our continued evolution as a species/planet.

It is with great love that the QEG is offered to the world, and as you take on the task of building one, it is hoped that this becomes your path also: the mission of free energy for all! The next step we ask you to take on your journey, before and during building, is to listen to the discussion here: <https://www.youtube.com/watch?v=eUMALIERkMo> with HopeGirl.

I am, in service to Gaia and its inhabitants, deeply grateful for this technology, and the opportunity to share it!

Valerie Robitaille

IMPORTANT ADDITIONAL INFORMATION

We are not professional writers or photographers and didn't always have opportunities to document or photograph every step of development. Therefore, please take the level of engineering/electrical experience required to build a QEG very seriously as we are giving these to you under this premise. You will discover the advanced level of knowledge of mechanical/electrical processes needed quickly enough. The correct construction of the QEG requires patience and careful thought. We made several mistakes in development and have given here the steps that were successful. You will probably still make mistakes – and these will be your greatest learning opportunities as you gain more knowledge about this type of energy.

Before beginning to build, consider how much you would like to outsource to one of the cottage industry community units (CICUs) near you! For now, **we recommend Torelco for purchasing a finished core (includes laminated steel core and rotor, all (mica) insulation components, magnet wire, sleeving, toroidal winding, spacer blocks, mylar tape and outer wrap tape, 8 inch through-bolts, nuts, washers, Nomex corner insulation, and the choice of potted windings (vacuum epoxy impregnation) or non-potted windings. Torelco currently has the best price we know of for a bare or completely processed core.** As FTW continues to roll out the distribution plan, and more connections across the world are made, CICUs are becoming more commonplace and hence, QEG parts are becoming more accessible (many people are building them!)

When website URLs were available we provided links for the person reading this online. If you are building a QEG, you may certainly use your own sources for materials, but we ask that you do not alter the information in this manual (other than for your own use). If you are skilled in the art of electromechanical design, then feel free to make improvements/modifications. We have no wish to control how you build this machine. In fact, we hope that you will experiment, develop, and improve the system (we are in a co-development process). We know with increased knowledge you will discover many applications for this technology.

When photographs can be shown to help you visualize a process, they are provided. Please remember, we are not professional manual writers. What we offer you here is the construction method we successfully used ourselves, free of charge and our gift to humanity – but it comes with great responsibility. Learn as much as you can, use discernment and wisdom, share freely, and you will be privileged to know the secrets of energy creation from the quantum field.

We would like to dedicate the success we've experienced to our first teacher, Sir Timothy Thrapp, and WITTS Ministries, without whose guidance none of this would be available so soon. We acknowledge and honor the work WITTS has done for over 200 years bringing alternative technology forward, and hope that you will consider making a donation to the ministry for their great work.

We would also like to thank our greatest teacher and fellow humanitarian, Nikola Tesla. It is our most gratifying honor to present modern plans for a quantum energy generator to the world, based on Tesla's discoveries, especially at a time when we the people are being manipulated and controlled by a corrupt energy economy. Tesla wanted everyone on the planet to have energy. We continue to carry out his vision.

PARTS LIST

(Updated 8-Feb-2015)

NOTE: All dimensions provided in both Metric and Imperial values where possible

Part	Type, Model # or MFG P/N	Quantity
Generator Core		
Stator	140 Laminations 24 gauge (.025") [0.64mm] type M19 Steel w/C5 coating, 3-1/2" stack, Welded, Bolted, or Bonded	(1) (See Drawing)
Rotor	(Cut at same time, from same lamination sheets as stator)	(1) (See Drawing)
Spacer Blocks 1-1/2" [38.1mm] x 1-1/2" [38.1mm] x 4-3/8" [111.125mm]	Aluminum 6061-T6, G10-FR4, Clear Polycarbonate, Accoya® Acetylated Wood	(8) (See Drawing)
8" [203.2mm] Bolts, 1/4" [M6] Ø, 1/4 -28 [M6x0.75] Thread, Grade 8 [Class 10.9]	Instock Fasteners P/N 1050095555	(8)
Nuts/Washers/Lockwashers	1/4 -28 [M6x0.75] Grade 8 [Class 10.9] Hex Nuts/Flat Washers/Split Lockwashers	(8 pcs. each)
Shafting 7/8" [22.225mm] dia. x 11.0" [279.4mm] Long w/Standard 3/16" [4.7625mm] x 3/32" [2.38125mm] Keyway	Trukey P/N C1045 TGP (turned/ground/polished)	7/8" [22.225mm] dia. x 11" [279.4mm] or 12" [304.8mm] length
Bonding Compound for Shaft to Rotor	LOCTITE 648 Retaining Compound (Cat. No. 64836)	(1) (50ml Bottle)
Primer/Activator (use with bonding compound)	Loctite 7471 (Cat. No.142474)	(1) (150ml Aerosol)
Bearings	4-Bolt Flange Mount, 7/8" Bore, P/N FC7/8-RHP (preferred), or 3-Bolt Flange Mount, 7/8" Bore, P/N SBTRD205-14G	(2)
Bearing Bolts	5/16" [M8] x 1-3/4" [44.45mm] Carriage Bolts	(6)
Nuts/Washers/Lockwashers	5/16" [M8] Hex Nuts/Flat Washers/Split Lockwashers	(6 pcs. each)
Mica Tape 1.00" [25.4mm] x 50YD [45.72M]	MICA77956X1X50	(2) Rolls
Magnet Wire #12 gauge	Round Wire, Type HTAIHSD REA Pulse Shield® Inverter Duty (critical part!)	~620' [188.976M] (19.8 lbs./1000')
Magnet Wire #20 gauge	Round Wire, Type HTAIHSD, REA Pulse Shield® Inverter Duty (critical part!)	~5200' [1584.96M] (3.1 lbs. [1.406kg] /1000' [304.8M])

Mica Plate	NEMA 6 (36" [.9144M] x 36" [.9144M] x .030" [0.762mm])	(16) (See Drawing)
PTFE (Teflon) Sleeving (tubing) for #20 HTAIHSD Wire	Alpha Wire P/N TFT20011 (natural)	(4) pieces (18" [457.2mm] each)
PTFE (Teflon) Sleeving (tubing) for #12 HTAIHSD Wire	Alpha Wire P/N TFT20019 (black)	(4) pieces (18" [457.2mm] each)
Tape, White, 1" [25.4mm] Fiberglass, Hi-Temp (outer wrap)	Intertape P/N RG48	(2) Rolls
Tape, 1" [25.4mm] High Cut-Through Strength Mylar (Polyester), or Kapton	3M P/N 850 (Mylar, 1.9 mil), or Caplinq P/N PIT2A/25.4 (Kapton, 2 mil, tan color)	(2) Rolls
Nomex Corner Insulation	Torelco (custom made)	(16) pcs., (DuPont Type 418)
End Plates and Shrouds		
Reinforced Resin Laminated or Cast Sheet Material (for 2 end plates)	G10/FR4 (preferred), Phenolic types CE or LE, or transparent (clear) Polycarbonate	(1) sheet ½" [12.7mm] thick x 3' [.9144M] x 4' [1.292M] (makes 2 plates). (See Drawing)
Reinforced Resin Laminated or Cast Sheet Material (shrouds)	G10/FR4 (preferred), Phenolic types CE or LE, or transparent (clear) Polycarbonate	(2) 1/8" [3.175mm] thick x 5.875" [149.225mm] Ø, with 7/8" [22.225mm] Ø hole dead center (See Drawing)
Mounting Rail		
Angle aluminum	1 ½" [38.1mm] x 1 ½" [38.1mm] x 4' [1.2192M] Long. 1/8" [3.175mm] Thick	(1)
Wood or Laminate Parts for Platform (Base)		
Generator Baseplate	18" [457.2mm] (W) x 36" [.9144M] (L) x 1.5" [38.1mm] (Thick)	(1) If using wood, make from 2 pcs. of ¾" [19.05mm] thick quality plywood. Bond (screw and glue) together with opposing grain direction
Core Mounting Shoe	6.5" [165.1mm] (W) x 15" [381mm] (L) x 1.5" [38.1mm] (Thick)	(1)
Lag Bolts (Generator Core to mounting shoe)	¼" [M6] x 2.5" [65mm]	(10)
Washers/Lockwashers	¼" [M6] Flat Washers/Split Lockwashers	(10 pcs each)
Drive System		
V-Belts and Pulleys		
V-Belt, Goodyear 4L430	GDYR_4L430 (cogged belt)	(1)

Pulley, 1 Groove, 3" [76.2mm] x 7/8" (or 5/8") Bore, Type A (Motor)	AK30 x 7/8" Bore (bore size could also be 5/8" to match motor shaft)	(1)
Pulley, 1 Groove 2.50" [63.5mm] x 7/8" Bore, Type A (Generator)	AK25 x 7/8"	(1)
Drive Motor		
DC PM Variable Speed, 1.0 HP, 2500 RPM, 90V or 180V armature (depending on selected system voltage)	5/8" or 7/8" shaft, with sliding or slotted base. Leeson Model # 4D28FK5 (90V armature), #4D28FK6 (180V armature)	(1)
Motor Mounting Bolts	5/16" [M8] x 2-1/4" [60mm] Carriage Bolts	(4)
Nuts/Washers/Lockwashers	5/16" [M8] Hex Nuts/Flat Washers/Split Lockwashers	(4 pcs. each)
Variac, 120/240V Input, 0-280V Output, 9.5 Amps	STACO Type 1520	(1)
Bridge Rectifier	# KBPC2510TW (1000 Volt, 25 Amp., Quick-Connect Terminals)	(1)
Switch, Start/Run	Carling # TIGM51-6S-BL-NBL (DPDT Center Off, 15 amp, 240V)	(1)
Capacitors		
Capacitor, Filter, optional anti-hum for drive motor (if needed)	W.W. Grainger #2MDZ6 (40uF, 440 VAC, quick-connect terminals)	(1)
Capacitors, Resonant Tank 0.15uF [150nF], 3000 Volt, Tubular Axial Polypropylene	Cornell Dubilier #940C (preferred) High dV/dt for pulse applications	(72) 8 capacitors x 9 rows for initial value of 0.169uF [169nF] (see "Description of Components" section)

Suppliers and Parts/Service List

[TORELCO](#) – Toroidal winding service and complete core processing ready to ship

[TESLA ENERGY SOLUTIONS](#) – Kits with all parts to build a QEG (minus the core).

[FASTENAL](#) – Retaining (bonding) compound - Loctite 648 (bonds rotor to shaft) with Loctite 7471 activator (or equivalent)

[EIS](#) – Mica Tape, 20 gauge & 12 gauge Magnet Wire

[MOUSER](#) – Capacitors, Variac, Rectifiers, Start/Run Switch, Electronic Parts

[MAUREY POWER TRANSMISSION](#) – V Belt Pulleys

[EMCO PLASTICS](#) – End plates/shrouds

[ASHEVILLE-SCHOONMAKER MICA](#) – Mica plates

[DISCOUNT STEEL](#) – Aluminum Spacer Blocks

[BRIGHTON BEST](#) – 8 in. bolts

[THE PLASTIC SHOP.CO.UK](#) – Clear acrylic tube for exciter coil

[BETECH.CO.UK](#) - Variable speed DC Motor (1 HP)

[THE BIG BEARING STORE](#) – 7/8” Three Bolt Flange Bearing w/set screws

[SIMPLY BEARINGS.CO.UK](#) – 7/8” Four Bolt Flange Bearing w/set screws (preferred)

MAJOR GENERATOR COMPONENTS

- Stator
- Rotor
- Insulation Components
- Magnet Wire
- Resonant Tank Capacitors
- Bearings
- End Plates
- Pulleys/V-Belt
- Drive Motor
- Bridge Rectifier
- Variac
- Base/Frame and packaging

Description of Components

THE STATOR, or generator core, is made using 140 laminations of 24 gauge (0.025”) type M19 electrical steel with C5 coating, forming a stack of 3-½ inches, with a 4 pole configuration. The corresponding **ROTOR** has 2 poles. Both STATOR and ROTOR stacks are tig welded in 4 places, however, it is not necessary to weld the lamination stack. This is done only to maintain alignment of the laminations during shipping and handling. The lamination stack can be welded, bonded, or simply bolted together.

End Plates

Fiberglass reinforced epoxy laminate (FR-4/G10) was used for end plate construction, but other types of laminate material can be used, such as Grade CE (cotton/epoxy), or Grade LE (Linen/epoxy). Clear polycarbonate (not acrylic) can also be used if you would like your end plates to be transparent. End plates must be constructed of insulating material, but must also be structurally strong as they support all generator components, including bearings, shaft, rotor and stator. FR4 is the same material used to make circuit boards and is very strong, machinable, and dimensionally stable. Dimensions: End Plates: 0.500” [12.7mm] Thk., 15” [381mm] X 16.5” [419.1mm] with 15” [381mm] radius and 2.450” [62.23mm] center hole. Please note: If using the preferred 4-bolt bearing housings, start with center hole diameter of 2-7/8” (2.875”) [73.025mm]. Center hole (and bearing mounting holes) may require further enlargement or slotting to provide sufficient bearing adjustability when centering rotor in stator bore.

Bearings

The bearings should have a narrow inner ring with set screws for attaching to the shaft. Housing is cast iron with a grease zerk for re-lubing the bearing. We used a particular 4-bolt flange type bearing/housing (see parts list) because it is very flat, and worked better for mounting bearings on the *inside* of the end plates (toward the rotor), but 2-bolt or 3-bolt bearings/housings can also be used. Bearings can also be mounted on the outside of the end plates, which may require the shaft to be slightly longer (12” [304.8mm] length should be sufficient in any case.

Resonant (Tank) Capacitors

The primary tank circuit capacitors are a critical part of the system. The initial capacitor bank configuration on our prototype uses 72 tubular film type caps, 0.15uF [150nF] each (see parts list). Each cap is rated for 3000V. The bank is configured with 9 parallel rows of 8 series wired capacitors. Each series string can withstand up to 24,000 Volts, and total capacitance value is adjusted by making and breaking the connections that parallel the rows (see included schematic “initial resonance cap value.pdf”, and cross-reference table “tank capacitor values.pdf”). The value of these capacitors will be adjusted to tune the frequency/RPM of the generator. Fine tuning (of small increments of capacitance value) can be accomplished by jumpering (or switching) single capacitors in or out *in series* with any of the 9 series strings of capacitors. This bank can be adjusted for values between about 0.019 and 0.169uF [19 and 169nF]. A value of about 0.169uF [169nF] will establish resonance near 2,400 RPM on the rotor shaft, which is in the ideal speed range for the machine’s mechanical setup. The machine in the Witts 40kW demo video is running at about 2450 RPM.

Ours is only a suggested capacitor bank configuration. Other setups may be designed and used according to your preference and budget. The best information we have at this point in development indicates experimental values will be between about 0.03 and 0.3uF [30 and 300nF], and the final capacitor value may be just around 0.1uF [100nF].

Variac

The variac is used to control the drive motor speed (rotor speed) which effectively controls the system power. It's used throughout the construction, development, tuning, and self-looping setup. Use of a variac is important when attempting to self-loop because the variac output is available *instantly* when the input is energized, and switching the motor (and variac) from mains supply to generator output must be done quickly to prevent the machine slowing down and dropping out of resonance before the switchover is complete. Electronic motor drives have a certain amount of delay before output is available after energizing the input. However, once self-looping is established, we'll know how much delay can be tolerated, so an electronic drive may be an option at that point, which would reduce the weight, bulk, and cost of the machine.

End Plate Layout

We used the bare core as a template to drill all the core mounting holes in the proper locations on the end plates. After end plates are cut and finished, place one on a flat work surface that will support up to 130 lbs. [about 60kg]. Place the bare core over the end plate, aligning the center bore of the core with the center hole in the end plate. When mounting the core on the endplates, it should be oriented with the pole pieces at 45° to the generator base for the lowest profile. Make sure the pole pieces are right to the edge of the radius at the top of the end plate. We used an extra long drill bit to drill the 8 mounting holes. Repeat this process for the other end plate. Alternately, a long 1/4" dia. pin with a sharpened end could be used as a center punch to mark hole locations and drill the holes using a drill press, or the CAD drawings could be used to program a CNC milling machine if you have access to a machine shop. If using the core as a template be sure to make assembly marks on the core and the end plate so that the final assembly will have all the parts in the same orientation and the mounting bolts will go through without binding. Be sure to mark the in-facing and out-facing sides of each panel.

CORE ASSEMBLY

We highly recommend ordering your generator set (stator and rotor) from an experienced professional lamination house using the included CAD drawings for fabrication. When your stator/rotor stack is completed (welded/bonded/bolted, and mounting holes drilled), bolt down the 8 spacer blocks using the 8" bolts with 1/4" nuts and washers (see parts list), then wrap the core with 2 types of tape: Overlapping 50%, wrap 1 layer of 1" reinforced (high-strength, high cut-through resistance) Mylar or Kapton tape around the steel core (round part), followed by 2 layers of mica tape. Wrap 1 more layer of Mylar or Kapton tape over the mica tape. Make sure all tape is butted right up against the 4 pole pieces. These 4 layers will bring the thickness needed for insulation to about 18 mil.

Installing Mica Plates and Corner Insulation

After you've cut 16 C-shaped mica plates, install them on the top and bottom of each pole piece (front and back). We used a small amount of contact cement to hold them in place for the rest of the processing (see photos), but they can also be taped in place with the reinforced Mylar tape. Mica plates (and corner insulation pieces) are installed after core taping and before winding. Make 16 pcs. of corner insulation from high voltage insulating paper (such as DuPont Nomex type 418 or equivalent) at 0.015 to 0.025" thickness. Install these in the corner between mica insulating plates and mica tape wrap (see drawing). This is provided by Torelco when ordering a fully-processed core. Be very mindful at the corners of the pole pieces making certain there is no opening in the insulation for the wire to fall down into contact with the bare steel. If this happens, the coil will be short-circuited.

Winding the Core

You will need to commission a toroidal winding service. They might agree to process the entire core if you supply the materials (mica tape and plates, corner insulation, spacer blocks, bolts/nuts/washers, Mylar and fiberglass tape, etc.). We also have 2 QEG groups who have built their own toroidal winding machines, and you could also wind by hand, although this would be very time consuming.

Teflon sleeving is installed on the first complete turn of each winding of both the #20 wire and the #12 wire. Two coils of 3100 turns each of #20 wire are wound on opposing sides (left and right), and 2 coils of 350 turns each of #12 wire on the other sides (top and bottom). Be sure you are using the Pulse Shield® (REA) or Ultrashield® (Essex) wire for both the #20 and the #12 wire (Please see included "Housing_View_Winding_Direction" drawing for proper wire lead orientation and winding direction). Proper winding is critical for the machine to be operational! Leave about 3 extra feet of wire at the start of each winding, and also at the finish for lead wires. Use enough sleeving to make sure the lead wires are completely insulated where they come through the rear end panel. Be sure to secure the finish leads of each coil so that they don't unravel during handling. Please note: The outer surface of the finished coils should be at least ¼" [6.35mm] away from being flush with the 6" rotor bore. In other words, a minimum of ¼" spacing should be maintained between the surface of the spinning rotor, and the surface of the windings. This is to prevent arcing to the rotor surface during operation.

Outer Wrap Taping

Wrap a single layer of 1" white fiberglass tape tightly and securely around each of the 4 coils, making sure that all wire is covered and tape is butted up against the 4 pole pieces.

Generator Assembly Steps

Rotor/Shaft/Shroud Assembly

Drawings are provided for the shaft in the CAD drawing package. The shaft length can be 11" (minimum), or 12" or more, depending on whether you mount your bearings on the inside or the outside of the end plates. We used Loctite 648 industrial adhesive (with activator) to mount the shaft to the rotor, which is effective for bonding close fitting metal parts.

Drill a 7/8" center hole, and two 1/4" mounting holes into the shroud disks (mounting holes are lined up with the holes in the rotor). Slide one disk onto the shaft on each side of the rotor. Bolt both shrouds to the rotor using two 4" or 4-1/4" long 1/4 - 28 through-bolts and nuts. Insert bolts in opposite directions according to the drawing. These bolts should not be any longer than necessary or a rotor imbalance can occur. Shrouds are used to quiet the windage noise generated by the spinning rotor. Optionally, the entire rotor assembly can be balanced at a reputable machine shop for smoothest operation. However, the machine shop should be instructed to remove material from the rotor very carefully, to prevent delaminating.

Bearings

We recommend mounting the bearings to the inside of the front and rear end plates. Center each bearing on the 2.450" hole (or 2.875" hole, depending on which bearing housing is used) in the center of the plate. Drill the holes oversize for the mounting bolts. This is done to provide adjustability in the position of the shaft at final assembly. The bearings will have to be moved slightly to center the rotor in the bore of the generator. The gap between rotor and stator is very small (.010" or less) and the rotor will need to be positioned so it does not rub on the stator bore. Only tighten finger tight at this time.

Core Assembly

We opted to bring the leads from the coils out directly through holes drilled in the rear end plate. You may decide to bring the leads out a different way. Here are the steps for our method:

1) Lay the pre-drilled front end plate (the one *without* the holes for the coil wire leads) on top of 4 wood blocks, 1-1/2" thick x 3-1/2" wide x 6" long (North American standard 2x4, 6" long) arranged in a cross, and placed on a flat work surface that can support up to 130 lbs. [about 60kg]. Position the wood blocks under the end plate evenly without covering any of the pre-drilled holes.

2) With an assistant or two, place the fully processed core (about 90 lbs.) down onto the pre-drilled end plate with the wire leads facing up. Line up the center bore of the core with the center hole in the end plate, then line up the mounting holes. Make sure the wire leads are oriented according to the included "Housing_View_Winding_Direction" drawing. Use a couple of long 1/4" rods or 2 of the long mounting bolts and push them through the stator, into 2 mounting holes on opposite sides of the end plate. In this way, line up all 8 mounting holes in the stator with all 8 mounting holes in the end plate, using the long rods or bolts.

3) Leaving the 2 rods (or bolts) in place momentarily to maintain alignment, insert the longer end of the rotor/shaft/shroud assembly through the stator bore and into the front pre-mounted bearing. Let the rotor assembly drop through the bearing gently to the bottom, then rotate it to align with 2 of the stator poles. Without moving the core, front end plate, or rotor, gently remove the 2 long alignment rods (or mounting bolts). Now take the *rear* end plate (with pre-mounted bearing) and fish the 8 lead wires through the pre-drilled holes, as you lower it over the end of the rotor shaft. Take care not to pinch, bunch up, or crush any of the wire leads as you lower it into place. Once the rear end plate is down in contact with the stator assembly, install the 4 *outer* mounting bolts, washers, and nuts, and tighten securely. The core assembly must now be placed upright to reach the 4 inner mounting bolts. With assistance, place the assembly upright onto the raised portion of the base (mounting shoe), and install the 4 inner mounting bolts.

Core Mounting

4) We used 5 lag bolts across the bottom of the end plates on each side to mount the assembly to the mounting shoe on the wood base/frame. Other methods could be employed for mounting the core assembly to the base, such as using angle aluminum rails across the bottom skirts of the end plates (see CAD drawing layouts).

Drive Motor

5) Mount the drive motor to the base/frame. We opted to remove the 4-bolt pedestal base supplied with the motor, in order to mount it onto the aluminum angle on the front of the base instead. We used one bolt (on the 'C' face) so the motor could simply pivot to provide easy belt tension adjustability, and we built a simple sliding spacer to support the rear of the motor.

6) Once the motor is mounted to the base, install the 3" pulley on the motor shaft using the set screws.

Rotor Adjustment

7) At this point the rotor position should be adjusted so that it spins freely inside the core without rubbing. This is where you may need to adjust the bearing positions repeatedly until the rotor spins freely. (The gap between the rotor and stator is .010" or less, making this step a little delicate). However, once the rotor is tightened in position it does not tend to move. Place the 2 ½" pulley on the generator shaft at this time; it can be used to turn the rotor by hand while adjusting its position.

Install V-Belt

8) Place the V-belt over both pulleys and position pulleys as close to the motor and the generator as possible. Both pulleys should be positioned an equal distance from the faces of the motor and generator to assure that the belt runs true.

Variac

9) The variac can be mounted on the base at this time. We used two 1/4 – 20 x 1" bolts with nuts to mount the variac to the aluminum angle. After all the components are mounted on the base, wiring and testing will be performed using the variac. (After set-up and testing is completed, we may be able to replace the variac with an electronic motor control circuit board (SCR drive) for less bulk and weight.

Final Assembly/Wiring

10) With all components mounted on the base, wiring can begin. Please follow the included schematic to make connections. We mounted a 12-position, 40 Amp rated barrier terminal strip on the base to support the external wiring connections (see photos).

Set-up and testing

***Wiring Notes:** The generator output (secondary) can be wired in series (220, 230-240V), or parallel (110, 115, 120V). For the series connection shown on the schematic, the start leads from each coil are connected together. This connection provides the highest voltage output from the windings. If using a parallel connection for lower voltage/higher current, be careful to connect the four leads with polarity opposed (start lead of one coil connected to finish lead of other coil).

The variac we used can be wired for 120 or 240 volt input, and provides 0-280 volts output, at up to 9.5 amps. This is a versatile variac and can be used with either a 120 or 240 volt system. The output of the variac is connected to a 1000 volt, 25 Amp full-wave bridge rectifier to power the variable speed DC drive motor. Optionally, a 30-50uF, 400-450 Volt filter capacitor can be added across the bridge rectifier to filter out any AC hum in the motor.

*Starting with the wiring setup as shown in the schematic, prepare the series/parallel capacitor bank, but do not connect to primaries at this time. This will prevent resonance momentarily. Connect input power to the variac. We started with a full 240 volt series wired system, but parallel 120 volt wiring can also be used.

Test mechanical assembly by spinning up the motor/rotor/belt and observing operation. Adjust variac voltage from zero to about $\frac{3}{4}$ through its range. The active rpm range is under 3000 rpm, so we don't need to spin very fast. Assure there is no stack rub (rotor scrubbing on stator), or other mechanical issues that need to be corrected for smooth operation.

*When proper mechanical operation is assured, connect the series/parallel capacitor bank. The recommended initial configuration of 72 (seventy-two) 0.15 uF (150nF), 3000 volt capacitors gives us .16875uF (168.75nF), that will withstand up to 24,000 volts. This initial value should be in the range to produce resonance at approx. 2400 RPM (about 160Hz). **Be sure to apply a load on the output of the generator at all times. We recommend starting with the generator output wired in series, and four (4) 100 Watt/240 Volt incandescent lamps wired in parallel for initial load.**

As the machine spins up to resonance, the sound will change, and the rotor speed will lock into the resonant frequency. At this point any further increase of the motor speed control will change the speed only slightly, but the additional mechanical power input will drive the core deeper into resonance, thereby increasing the power output. With a single control, the voltage and current (power) can be increased or decreased.

In the QEG, the exciter coil is precisely tuned to 1.3 MHz resonant frequency. The exciter coil is a form of antenna, which effectively provides a conduction path from the quantum field (zero point) into the generator core. This has the effect of polarizing and electrifying the core, which increases power output. After the QEG is first built, the spark gap on the exciter coil should be adjusted (with power off) to between .005" and .010". Start the generator and let it spark for 2-3 seconds, and repeat this 4 or 5 times. Do this whenever starting the generator for the first few weeks of operation.

* *Denotes drawing included* For a better understanding of what we are trying to do with the exciter coil, please go here: http://home.netcom.com/~sbyers11/RFenergy_lono.html

THIS MATERIAL IS OPEN SOURCED BY THE FIX THE WORLD ORGANIZATION. THIS DOCUMENT MAY BE OPENLY REPRODUCED OR TRANSFERED WITHOUT LIMIT OR CONSENT OF THE FIX THE WORLD ORGANIZATION.

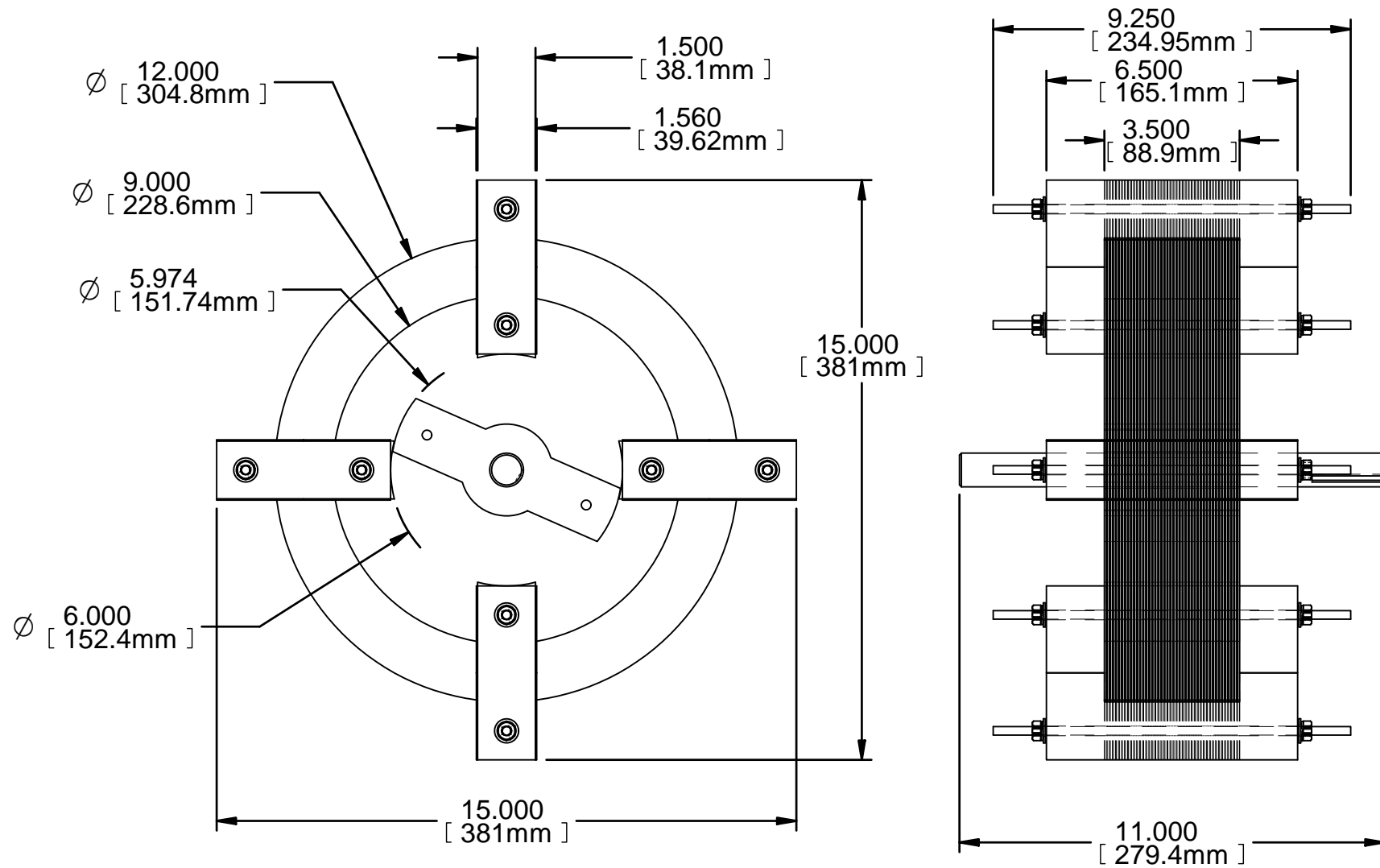

Rev.	Description	Date	Init.
1	Updated Consent Notice	03.24.15	IR

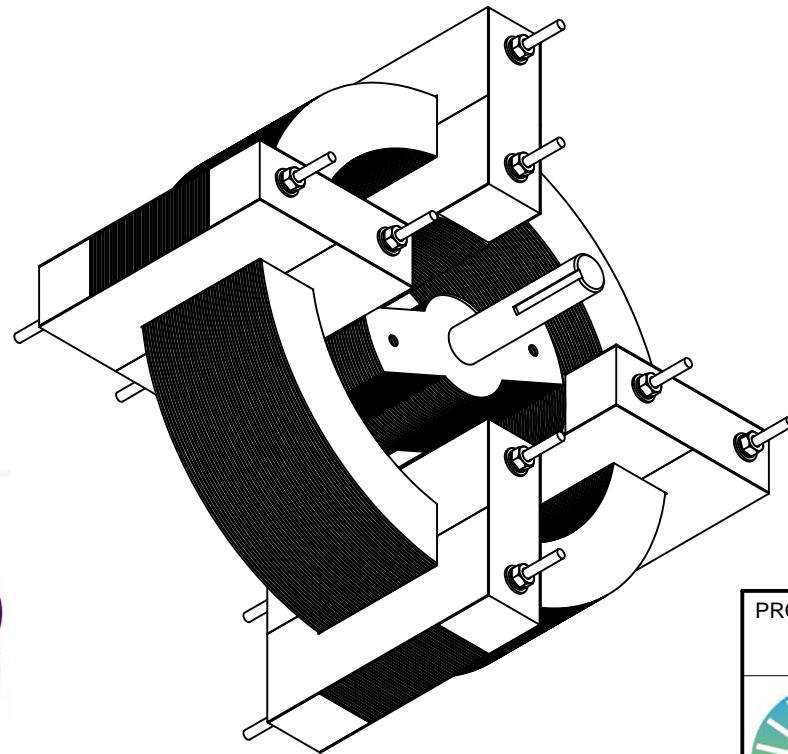
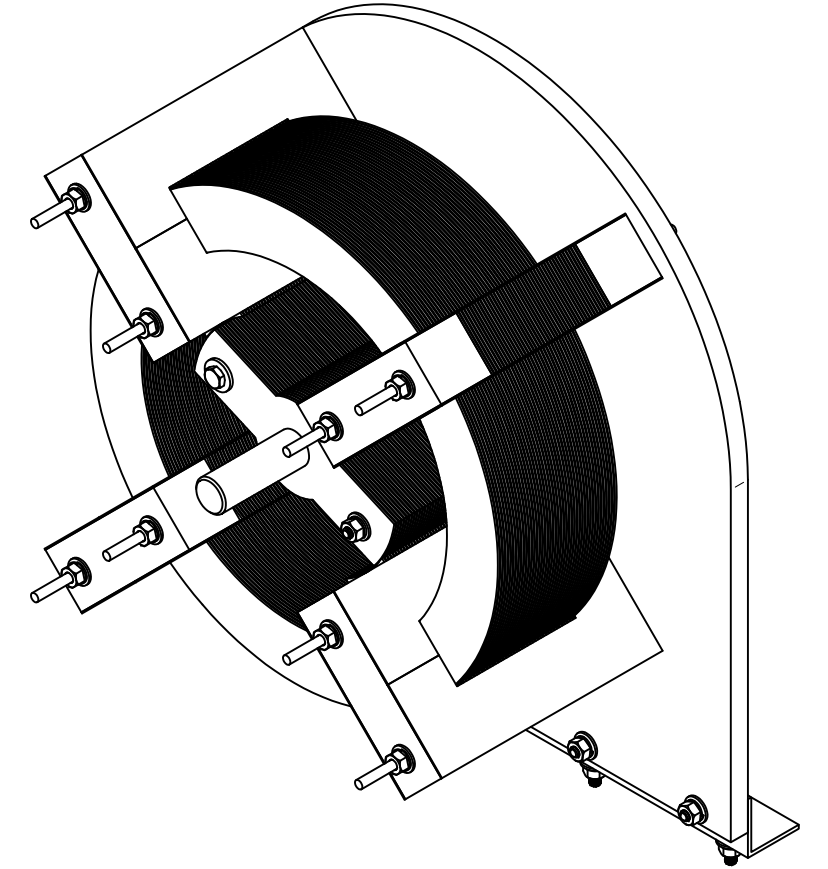

PROJ. NAME:	101	P/N:	A1000
Quantum Energy Generator CATSKILLS NEW YORK			

UNLESS OTHERWISE SPECIFIED:		COMPUTER FILE LOC: C:\FTW\101\Mech\A1000, Main, GA, pg1.DFT	
XX +/- .020 XXX +/- .005 XXXX +/- .0005 ANGLES +/- 3 DEG. FRACTIONAL TOL: +/- 1/64 ALL DIM'S ARE IN INCHES		TITLE:	
10KW Quantum Energy Generator			
MATERIAL:	DRAWN BY: Ivan Rivas	DATE: 03.24.15	CHECKED BY: DATE:
FINISH:	DESIGNED BY: James Robitaille	DATE:	APPROVED BY: DATE:
WEIGHT:	Q'TY/ASS'Y: 1	SCALE: 1 : 4	DWG. No: B-0-101-A1000
			REV. 1

THIS MATERIAL IS OPEN SOURCED BY THE FIX THE WORLD ORGANIZATION. THIS DOCUMENT MAY BE OPENLY REPRODUCED OR TRANSFERRED WITHOUT LIMIT OR CONSENT OF THE FIX THE WORLD ORGANIZATION.

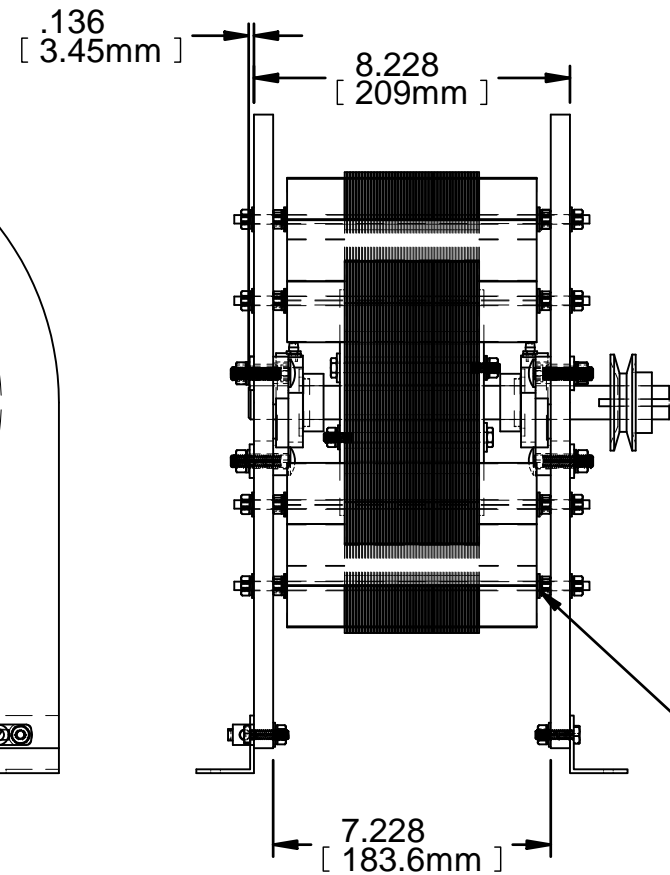
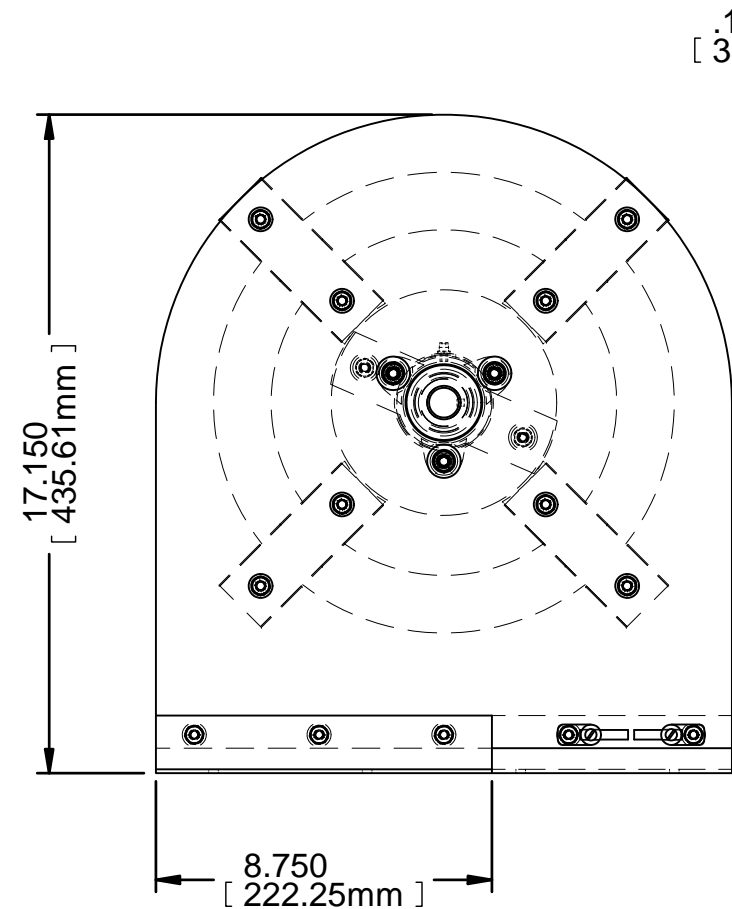

These nuts/ washers can be removed before assembling end plates. Leaving them on will provide more room for windings, but longer bolts would be necessary.

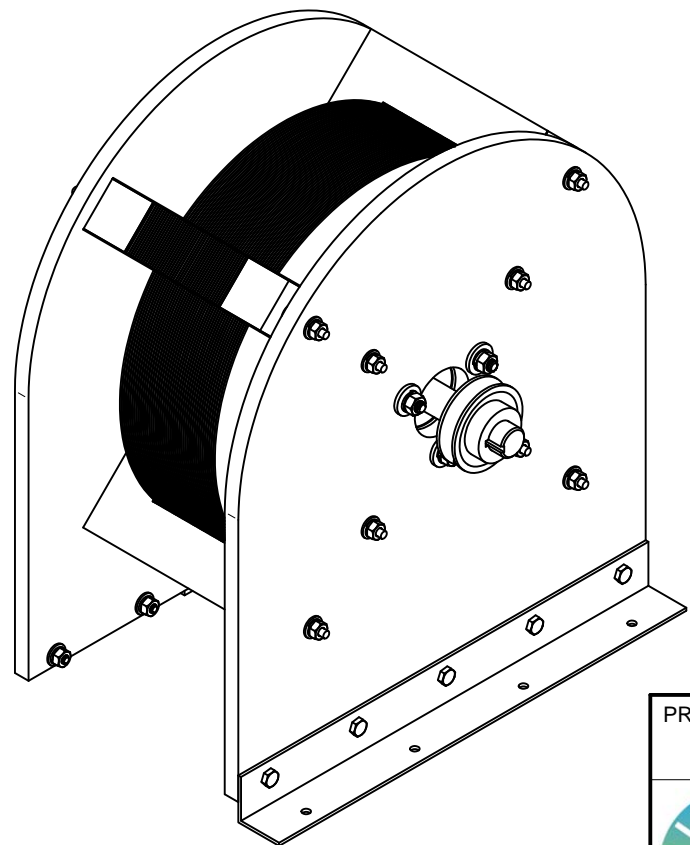

Rev.	Description	Date	Init.
1	Updated Consent Notice	03.24.15	IR

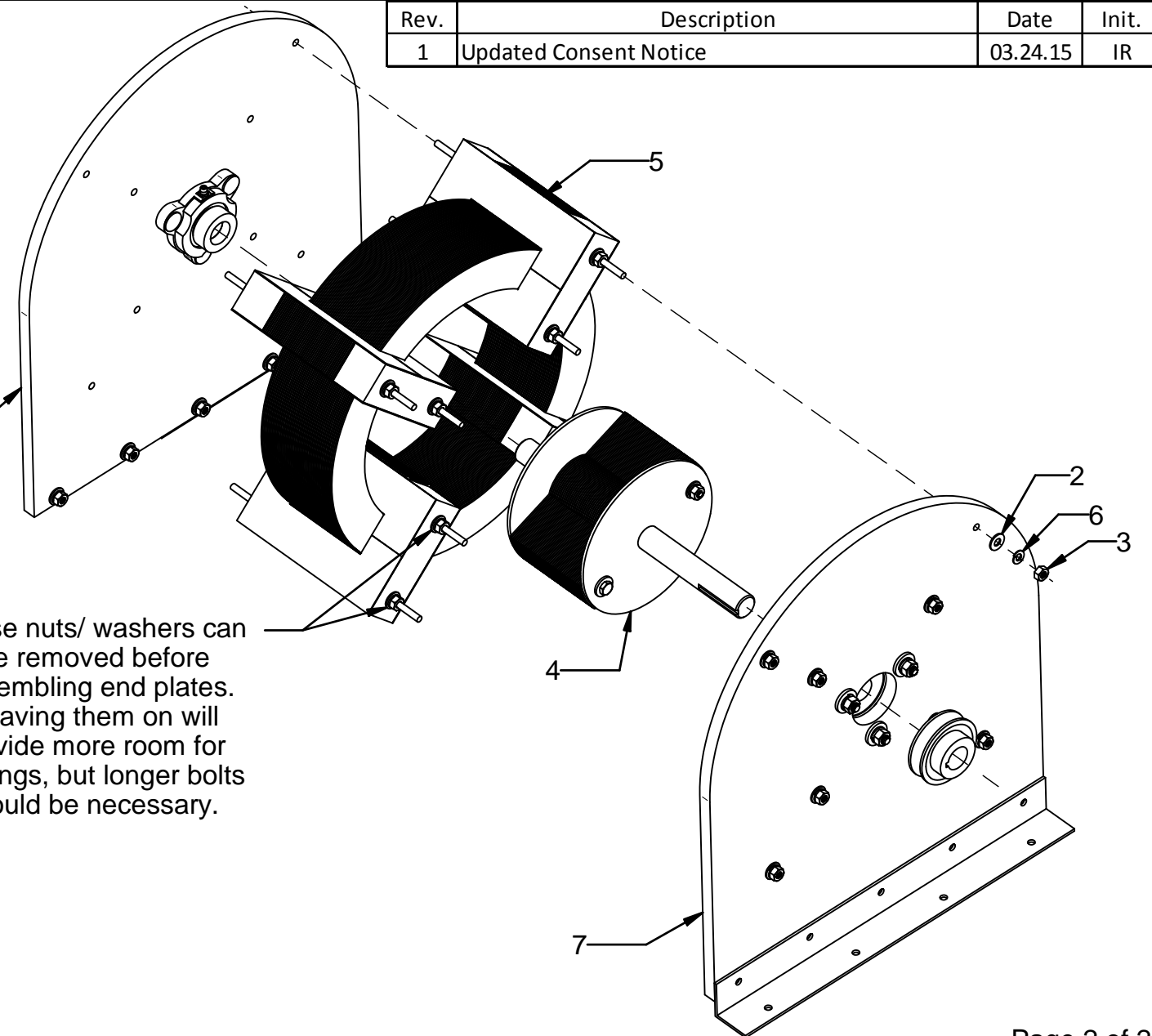

#	P/N	Qty	Description
7	P1037	1	Plate, End, Assy
6	P1015	16	Washer, Split, Lock, 1/4
5	A1008	1	Stator Assy
4	A1007	1	Rotor Assy
3	P1006	16	Nut, Hex, 1/4-20
2	P1005	16	Washer, Flat, #1/4
1	A1016	1	Plate, End, Gap Protection, Assy



PROJ. NAME: 101 P/N: A1000

UNLESS OTHERWISE SPECIFIED: XX +/- .020 XXX +/- .005 XXXX +/- .0005 ANGLES +/- 3 DEG. FRACTIONAL TOL: +/- 1/64 ALL DIM'S ARE IN INCHES		COMPUTER FILE LOC: C:\FTW\101\Mech\A1000, Main, GA, pg2.DFT	
MATERIAL:		TITLE: 10KW Quantum Energy Generator	
FINISH:	WEIGHT:	DRAWN BY: Ivan Rivas	DATE: 03.24.15
		CHECKED BY:	DATE:
		DESIGNED BY: James Robitaille	DATE:
		APPROVED BY:	DATE:
		Q'TY/ASSY: 1	SCALE: 1 : 5
		DWG. No: B-1-101-A1000	REV. 1

THIS MATERIAL IS OPEN SOURCED BY THE FIX THE WORLD ORGANIZATION. THIS DOCUMENT MAY BE OPENLY REPRODUCED OR TRANSFERRED WITHOUT LIMIT OR CONSENT OF THE FIX THE WORLD ORGANIZATION.

Rev.	Description	Date	Init.
1	Updated Consent Notice, and note	03.24.15	IR

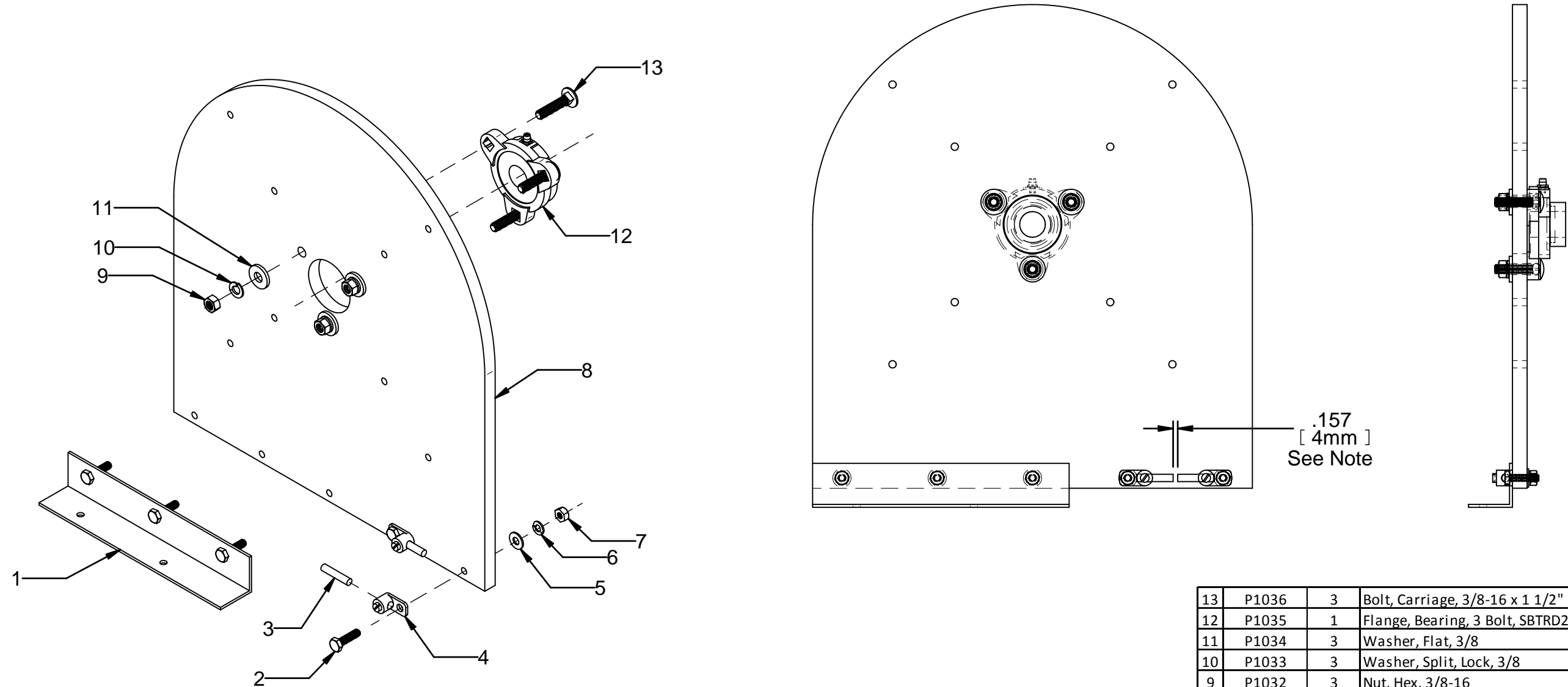

Note

1. Protection Gap for Capacitor Bank; A2 rod offset gap should be between 4mm - 6mm for testing. (basically a spark gap across capacitor bank. Running the machine with no load or too much load can cause arcing and short circuit in the core. Set gap at 4mm initially, then adjust for desired firing voltage. Ex. 4mm = 12kV ... 6mm=18kV, etc. (Gap opening 3mm = 1kV, or 3mm per kV)

13	P1036	3	Bolt, Carriage, 3/8-16 x 1 1/2"
12	P1035	1	Flange, Bearing, 3 Bolt, SBTRD205-14G 7/8"
11	P1034	3	Washer, Flat, 3/8
10	P1033	3	Washer, Split, Lock, 3/8
9	P1032	3	Nut, Hex, 3/8-16
8	P1014	1	Plate, End
7	P1006	5	Nut, Hex, 1/4-20
6	P1015	5	Washer, Split, Lock, 1/4
5	P1005	5	Washer, Flat, 1/4
4	P1031	2	Connector, Copper, L70
3	P1030	2	Rod, Drill, A2, 1/4" Dia. x 1.25"
2	P1029	7	Screw, Hex, 1/4-20 x 1"
1	P1028	1	Bracket, Angle, L, 1.5" x 1.5" x 8.75"
#	P/N	Qty	Description



PROJ. NAME:	101	P/N:	A1016

UNLESS OTHERWISE SPECIFIED:		COMPUTER FILE LOC: C:\FTW\101\Mech\A1016, Plate, End, Gap protx.DFT	
XX +/- .020 XXX +/- .005 XXXX +/- .0005 ANGLES +/- 3 DEG. FRACTIONAL TOL: +/- 1/64 ALL DIM'S ARE IN INCHES		TITLE: End Plate Assy, Protection Gap Side 10KW Quantum Energy Generator	
MATERIAL:	DRAWN BY: Ivan Rivas	DATE: 03.24.15	CHECKED BY: DATE:
FINISH:	DESIGNED BY: James Robitaille	DATE:	APPROVED BY: DATE:
WEIGHT:	Q'TY/ASSY: 1	SCALE: 1 : 4	DWG. No: B-0-101-A1016 REV. 1

THIS MATERIAL IS OPEN SOURCED BY THE FIX THE WORLD ORGANIZATION. THIS DOCUMENT MAY BE OPENLY REPRODUCED OR TRANSFERRED WITHOUT LIMIT OR CONSENT OF THE FIX THE WORLD ORGANIZATION.

Rev.	Description	Date	Init.
1	Updated Consent Notice	03.24.15	IR

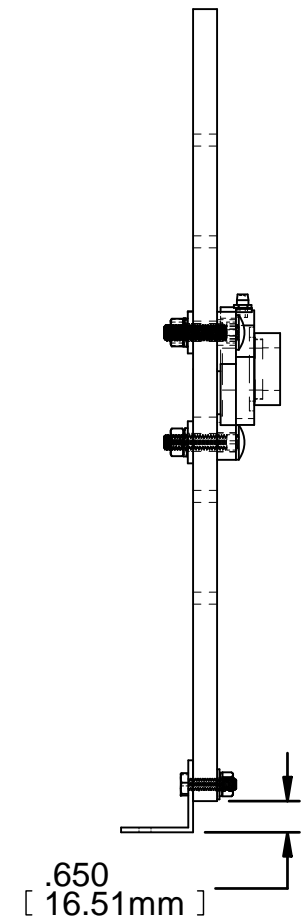
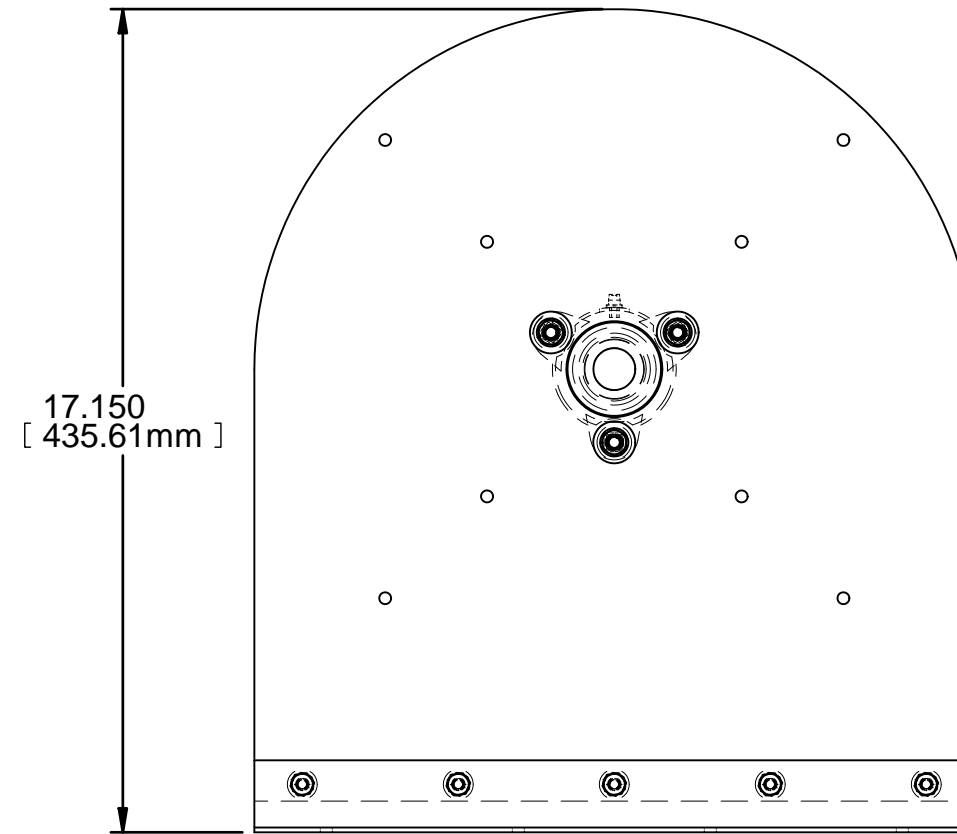
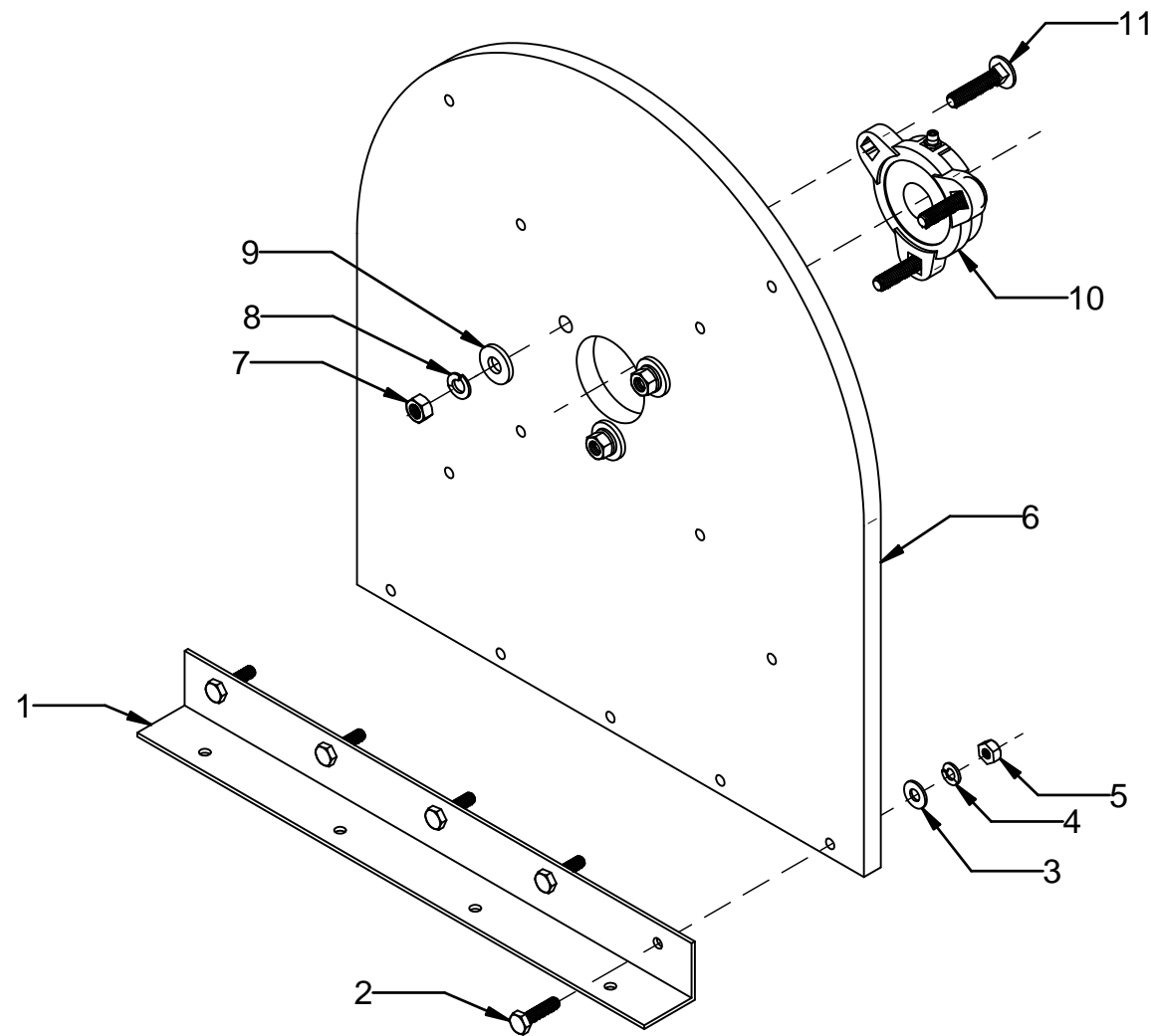

11	P1036	3	Bolt, Carriage, 3/8-16 x 1 1/2"
10	P1035	1	Flange, Bearing, 3 Bolt, SBTRD205-14G 7/8"
9	P1034	3	Washer, Flat, 3/8
8	P1033	3	Washer, Split, Lock, 3/8
7	P1032	3	Nut, Hex, 3/8-16
6	P1014	1	Plate, End
5	P1006	5	Nut, Hex, 1/4-20
4	P1015	5	Washer, Split, Lock, 1/4
3	P1005	5	Washer, Flat, 1/4
2	P1029	5	Screw, Hex, 1/4-20 x 1"
1	P1028	1	Bracket, Angle, L, 1.5" x 1.5" x 15"
#	P/N	Qty	Description



PROJ. NAME: 101 P/N: A1037

UNLESS OTHERWISE SPECIFIED: XX +/- .020 XXX +/- .005 XXXX +/- .0005 ANGLES +/- 3 DEG. FRACTIONAL TOL: +/- 1/64 ALL DIM'S ARE IN INCHES		COMPUTER FILE LOC: C:\FTW\101\Mech\A1037, Plate, End, Pully side.DFT	
MATERIAL:		TITLE: End Plate Assy, Pully Side 10KW Quantum Energy Generator	
FINISH:	WEIGHT:	DRAWN BY: Ivan Rivas	DATE: 03.24.15
		CHECKED BY:	DATE:
		DESIGNED BY: James Robitaille	APPROVED BY:
		Q'TY/ASSY: 1	SCALE: 1 : 4
		DWG. No: B-0-101-A1037	REV. 1

THIS MATERIAL IS OPEN SOURCED BY THE FIX THE WORLD ORGANIZATION. THIS DOCUMENT MAY BE OPENLY REPRODUCED OR TRANSFERRED WITHOUT LIMIT OR CONSENT OF THE FIX THE WORLD ORGANIZATION.

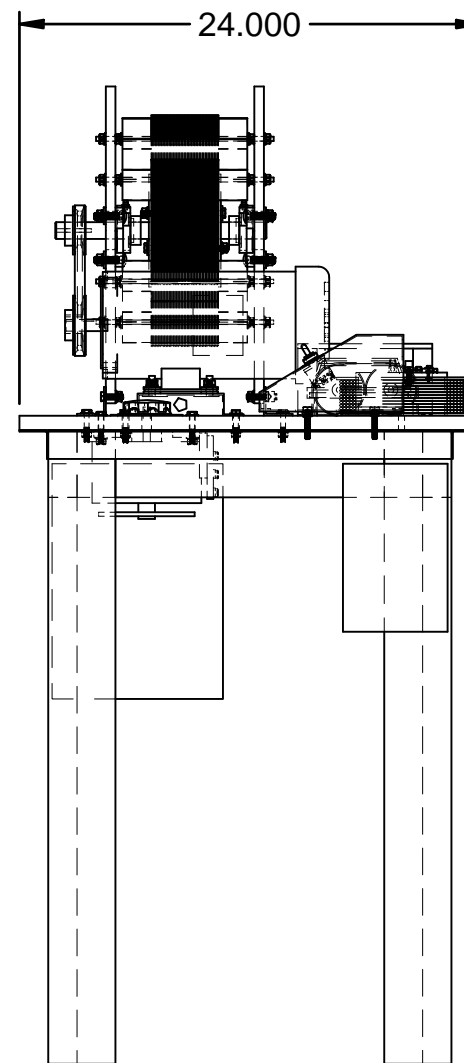
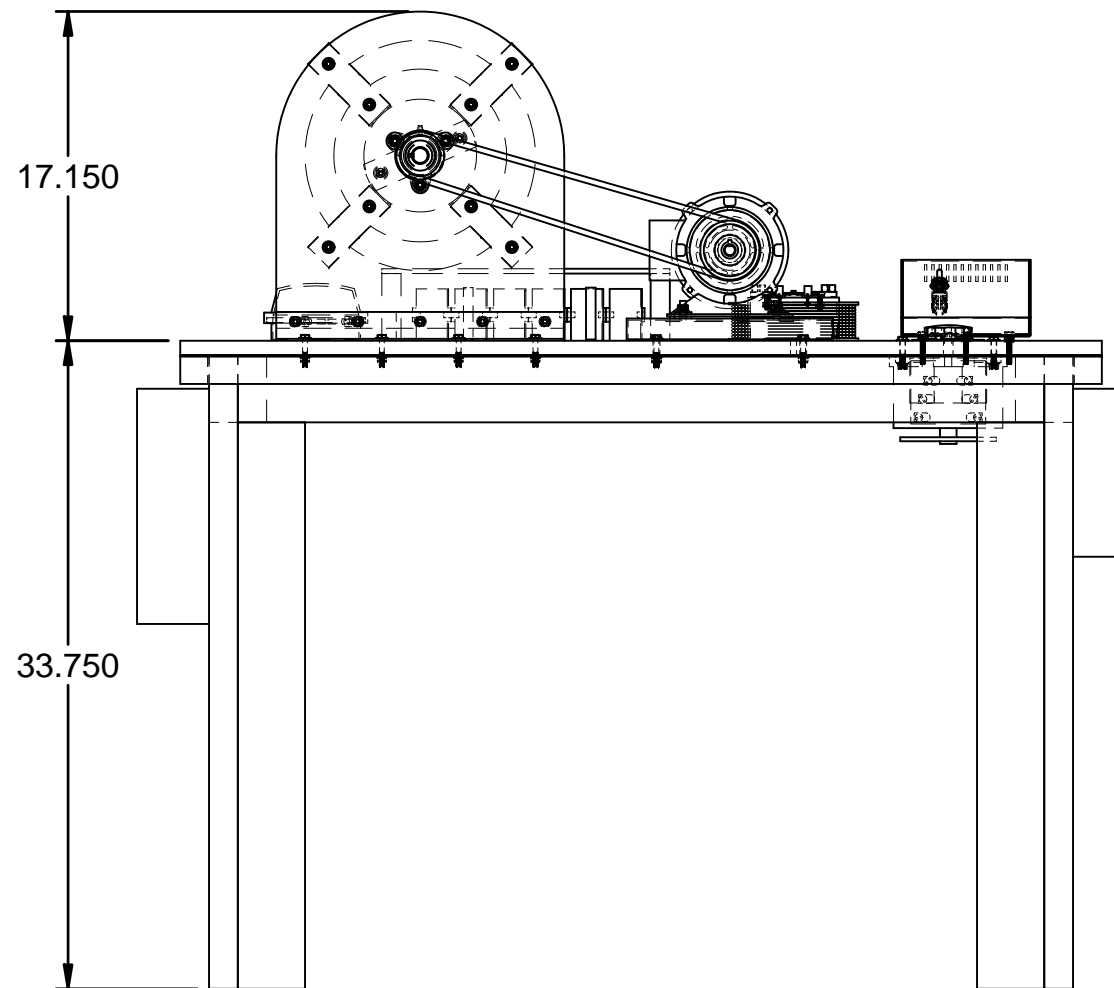
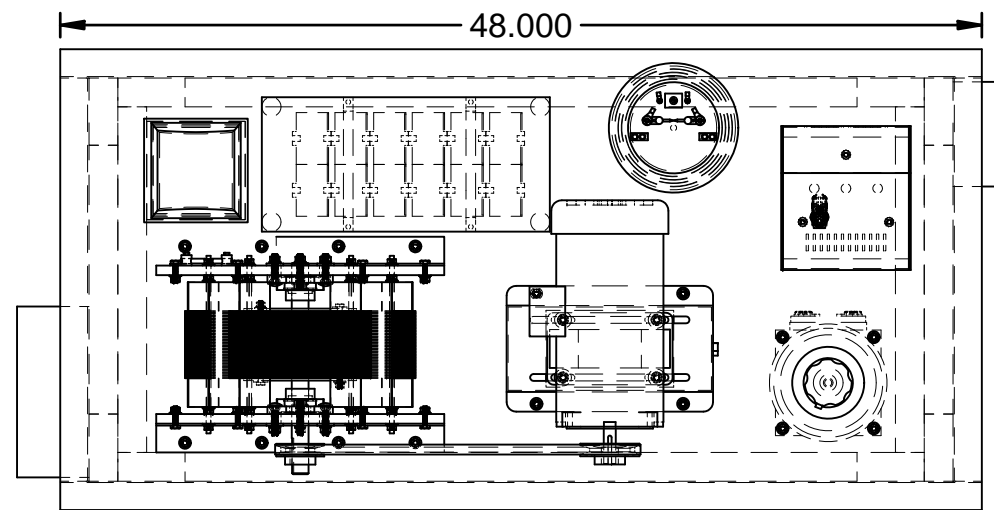

Rev.	Description	Date	Init.
1	Updated Exciter Coil Design	03.25.15	IR

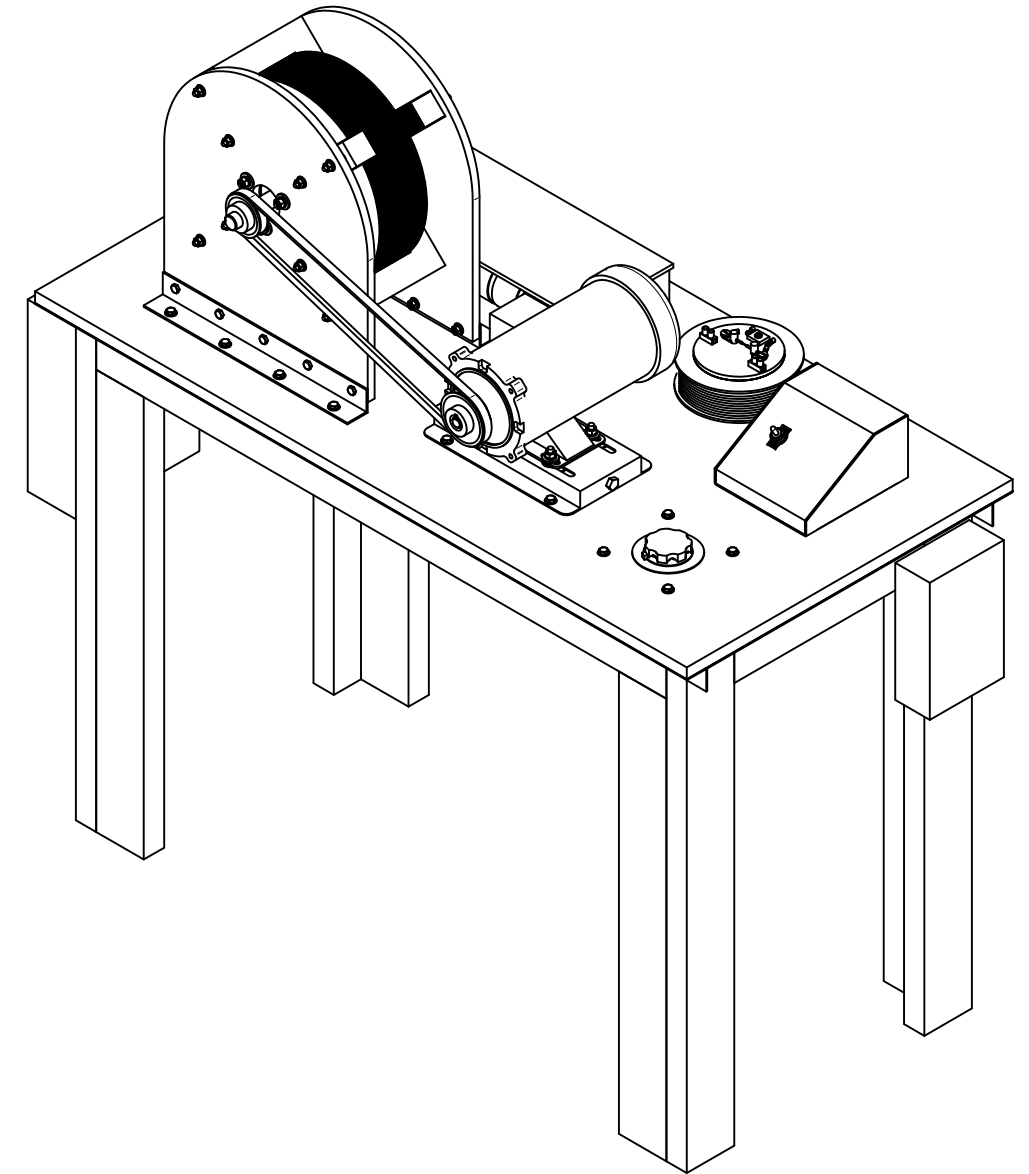

Quantum Energy Generator
CATSKILLS | NEW YORK

PROJ. NAME:	101	P/N:	A1018
-------------	-----	------	-------

UNLESS OTHERWISE SPECIFIED:

XX +/- .020
XXX +/- .005
XXXX +/- .0005
ANGLES +/- 3 DEG.
FRACTIONAL TOL: +/- 1/64
ALL DIM'S ARE IN INCHES

COMPUTER FILE LOC: C:\FTW\101\Mech\A1018, QEG, Fixture, pg1.DFT

TITLE:

QEG Prototype Fixture

MATERIAL:	DRAWN BY: Ivan Rivas	DATE: 03.25.15	CHECKED BY:	DATE:
FINISH:	DESIGNED BY: James Robitaille	DATE:	APPROVED BY:	DATE:
WEIGHT:	Q'TY/ASS'Y: 1	SCALE: 1 : 10	DWG. No: B-0-101-A1018	REV. 1

THIS MATERIAL IS OPEN SOURCED BY THE FIX THE WORLD ORGANIZATION. THIS DOCUMENT MAY BE OPENLY REPRODUCED OR TRANSFERRED WITHOUT LIMIT OR CONSENT OF THE FIX THE WORLD ORGANIZATION.

Rev.	Description	Date	Init.
1	Updated Exciter Coil Design	03.25.15	IR

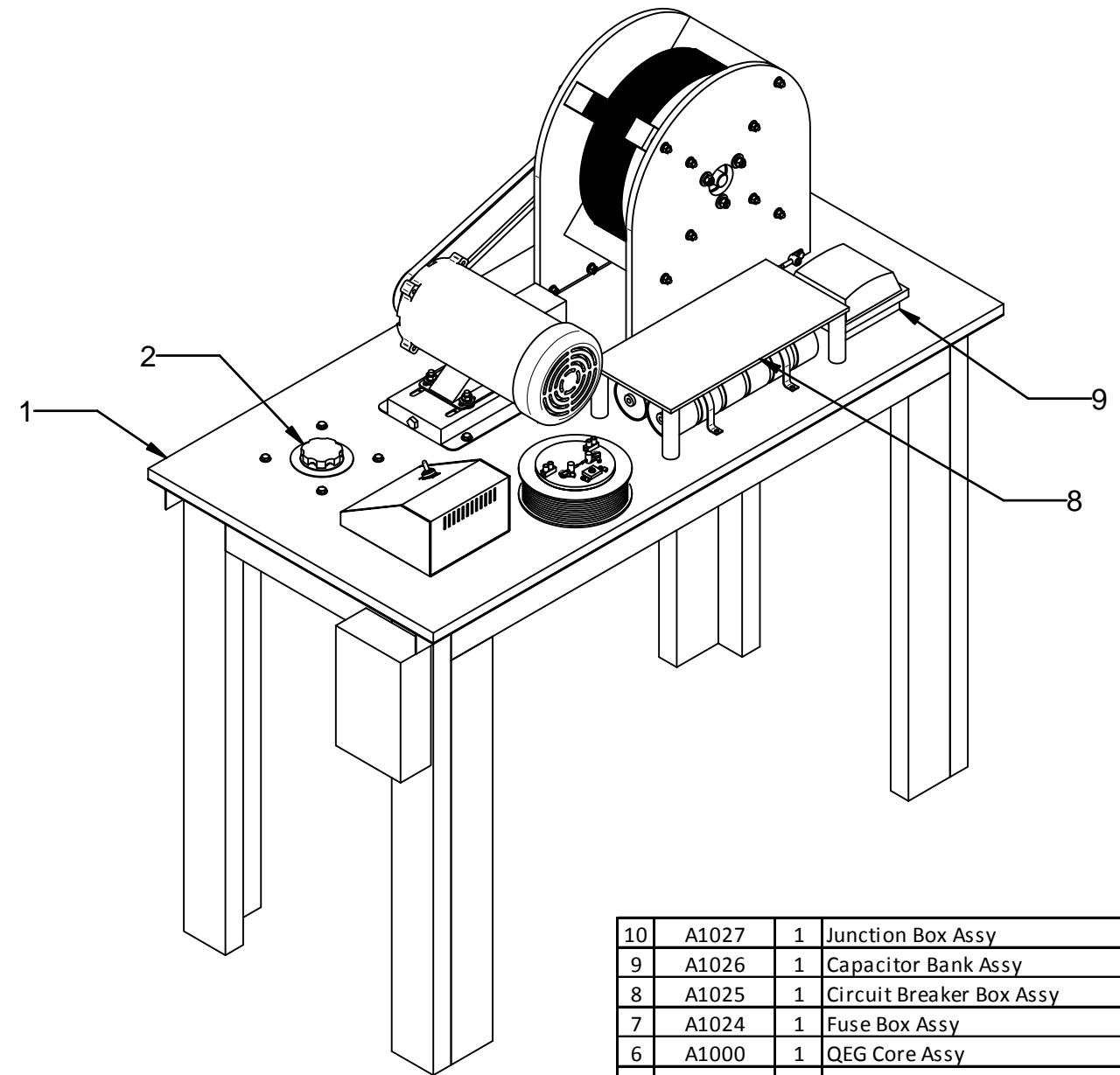
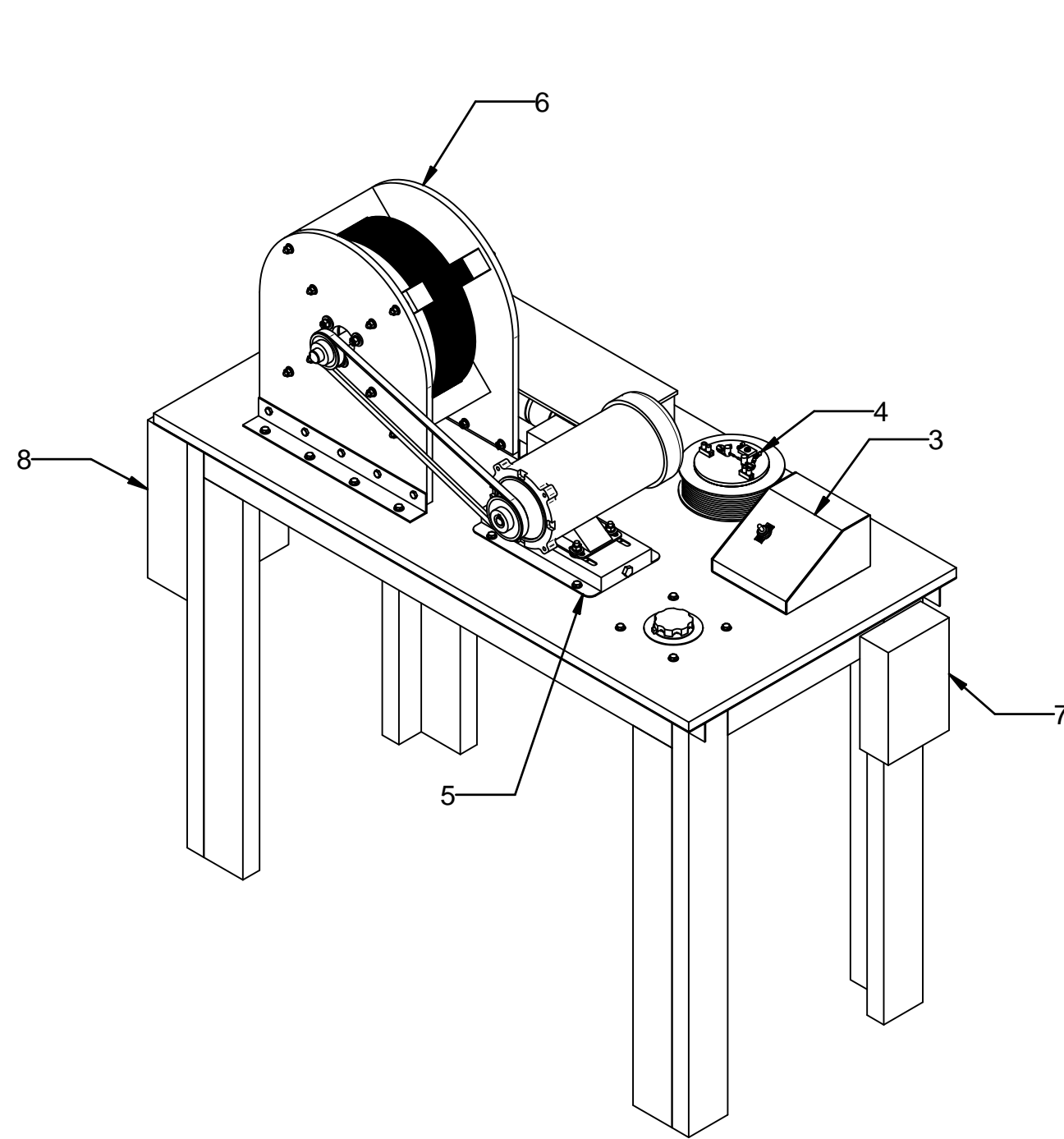

#	P/N	Qty	Description
10	A1027	1	Junction Box Assy
9	A1026	1	Capacitor Bank Assy
8	A1025	1	Circuit Breaker Box Assy
7	A1024	1	Fuse Box Assy
6	A1000	1	QEG Core Assy
5	A1023	1	Motor Assy
4	A1022	1	Exciter Assy
3	A1021	1	Switch Box Assy
2	A1020	1	Variac Assy
1	A1019	1	Wood Bench Assy

Page 2 of 2

PROJ. NAME:	101	P/N:	A1018
 Quantum Energy Generator CATSKILLS NEW YORK			

UNLESS OTHERWISE SPECIFIED:
 XX +/- .020
 XXX +/- .005
 XXXX +/- .0005
 ANGLES +/- 3 DEG.
 FRACTIONAL TOL: +/- 1/64
 ALL DIM'S ARE IN INCHES

COMPUTER FILE LOC: C:\FTW\101\Mech\A1018, QEG, Fixture, pg2.DFT

TITLE: **QEG Prototype Fixture**

MATERIAL:	DRAWN BY: Ivan Rivas	DATE: 03.25.15	CHECKED BY:	DATE:
FINISH:	DESIGNED BY: James Robitaille	DATE:	APPROVED BY:	DATE:
WEIGHT:	Q'TY/ASSY: 1	SCALE: 1 : 10	DWG. No: B-1-101-A1018	REV. 1



THIS MATERIAL IS OPEN SOURCED BY THE FIX THE WORLD ORGANIZATION. THIS DOCUMENT MAY BE OPENLY REPRODUCED OR TRANSFERRED WITHOUT LIMIT OR CONSENT OF THE FIX THE WORLD ORGANIZATION.

Rev.	Description	Date	Init.
1	Updated consent Notice, Removed SS from Hardware	03.25.15	IR

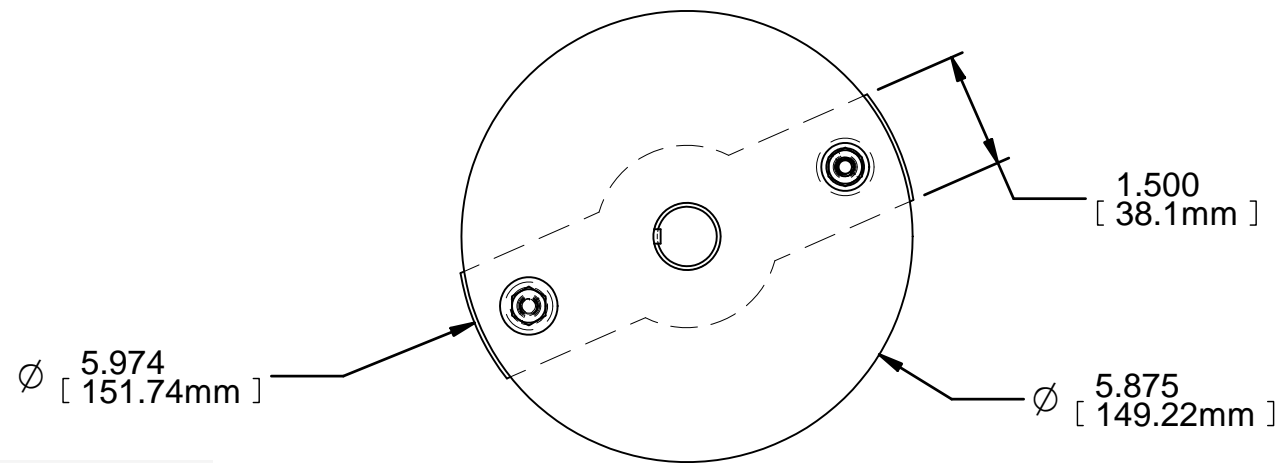
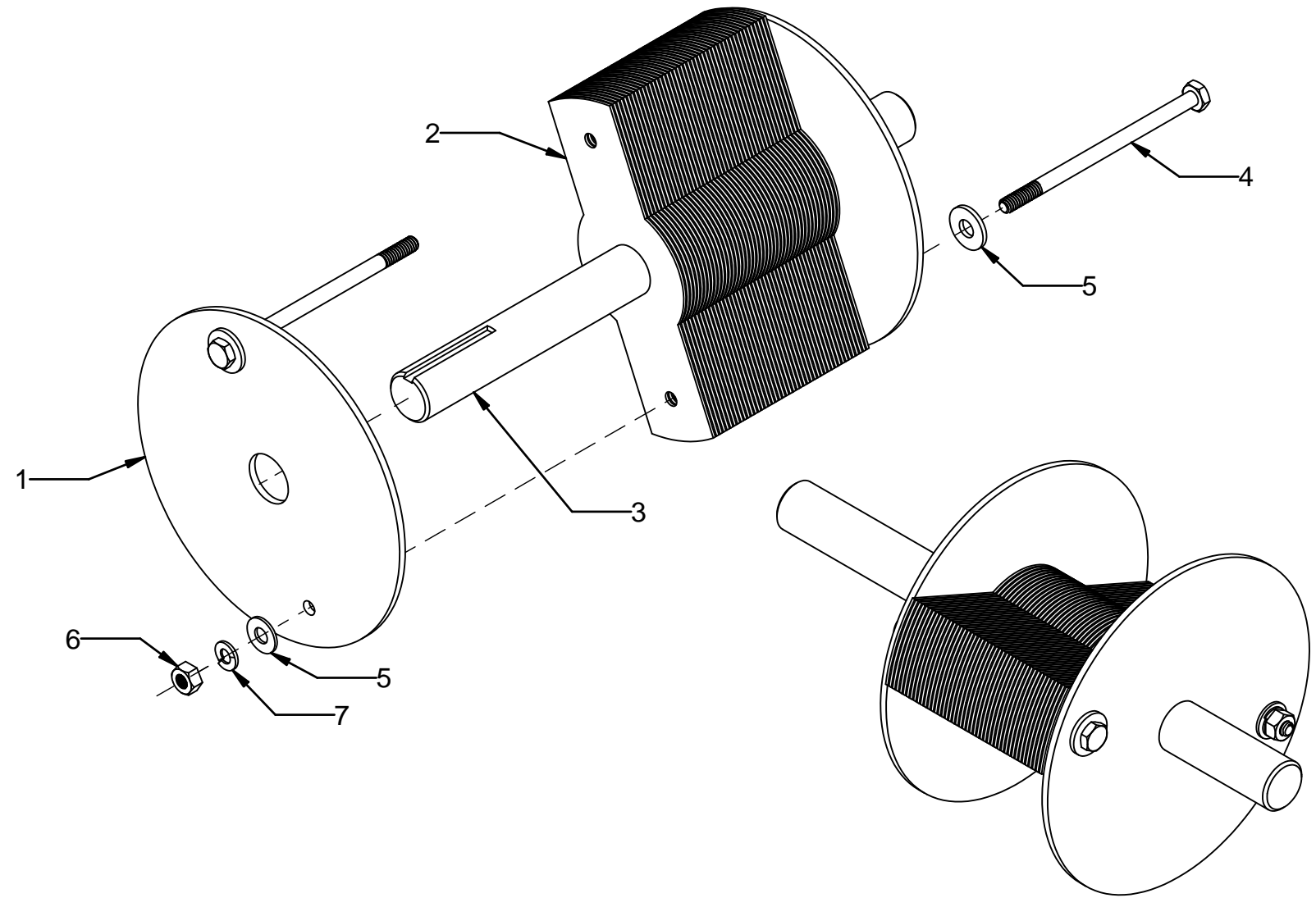
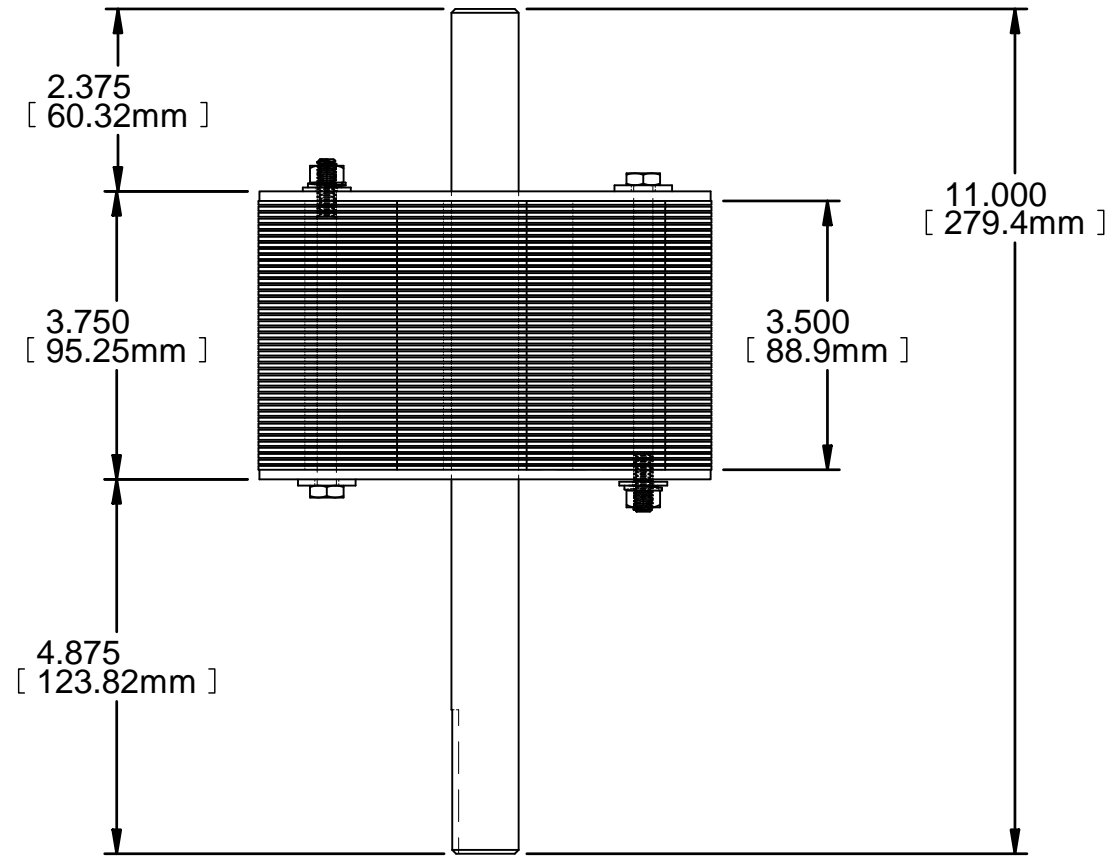

#	P/N	Qty	Description
7	P1015	2	Washer, Split, Lock, 1/4
6	P1006	2	Nut, Hex, 1/4-20, Grade 8
5	P1005	4	Washer, Flat, #1/4
4	P1004	2	Bolt, Hex, 1/4-20 x 4-1/4, Grade 8
3	P1003	1	Shafting, 7/8" Dia x 11" Long, w/ standard 3/16" x 3/32" Keyway, C1045 TGP Trukey
2	P1002	140	Lamination, Rotor, 24 Gauge, M19 C5, Electrical Steel
1	P1001	2	Shroud, Mat.: (Fiberglass, Laminate, epoxy, Reinforced, 1/8" thk x 5.875" Diameter

UNLESS OTHERWISE SPECIFIED:		COMPUTER FILE LOC: C:\FTW\101\Mech\A1007, Rotor, Main, GA.DFT	
XX +/- .020 XXX +/- .005 XXXX +/- .0005 ANGLES +/- 3 DEG. FRACTIONAL TOL: +/- 1/64 ALL DIM'S ARE IN INCHES		TITLE: Rotor Assy 10KW Quantum Energy Generator	
MATERIAL:	DRAWN BY: Ivan Rivas	DATE: 03.25.15	CHECKED BY: DATE:
FINISH:	DESIGNED BY: James Robitaille	DATE:	APPROVED BY: DATE:
WEIGHT:	Q'TY/ASSY: 1	SCALE: 1 : 2.5	DWG. No: B-0-101-A1007 REV. 1

PROJ. NAME:	101	P/N:	A1007
-------------	-----	------	-------



THIS MATERIAL IS OPEN SOURCED BY THE FIX THE WORLD ORGANIZATION. THIS DOCUMENT MAY BE OPENLY REPRODUCED OR TRANSFERRED WITHOUT LIMIT OR CONSENT OF THE FIX THE WORLD ORGANIZATION.

Rev.	Description	Date	Init.
1	Updated consent Notice	03.25.15	IR

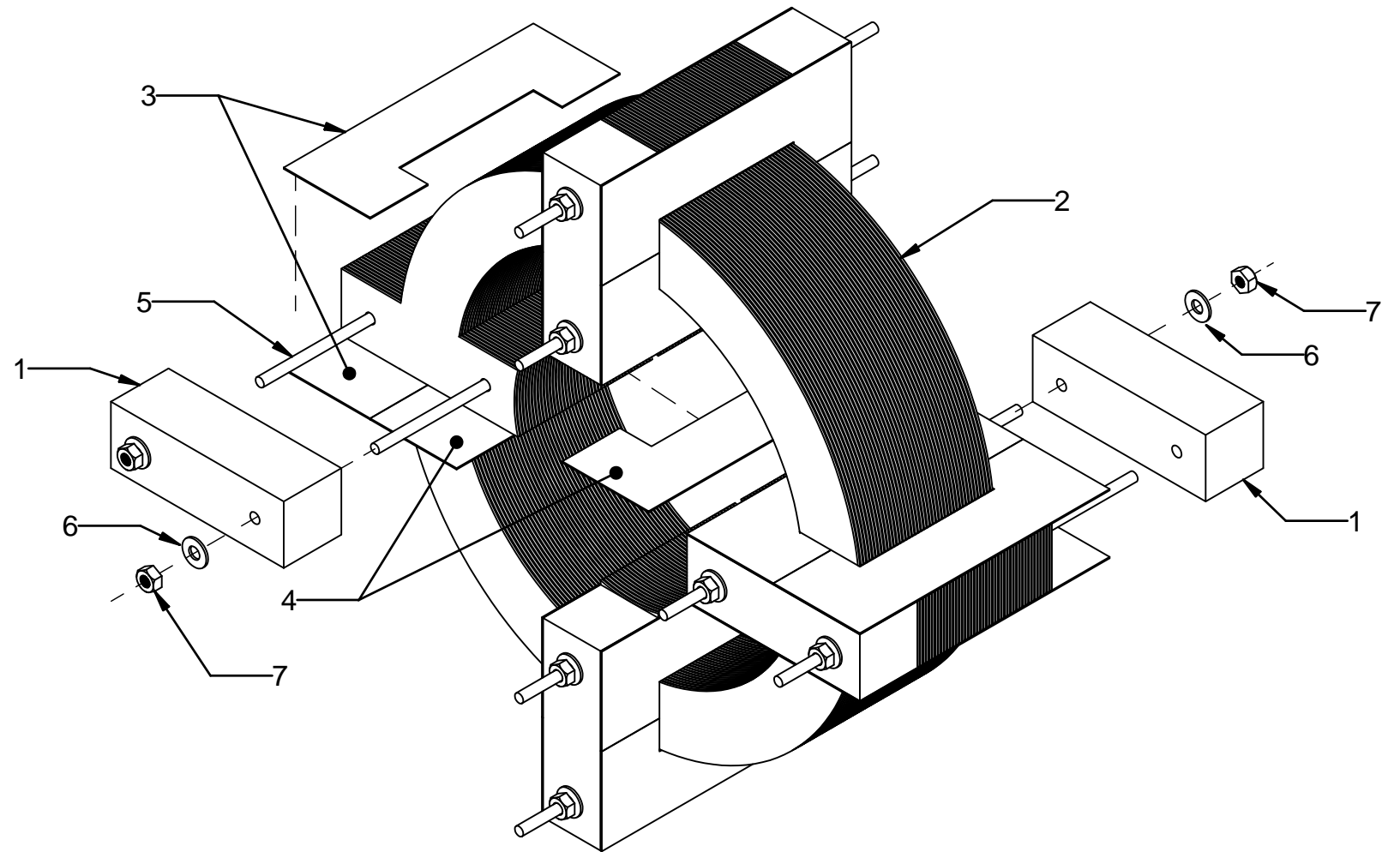
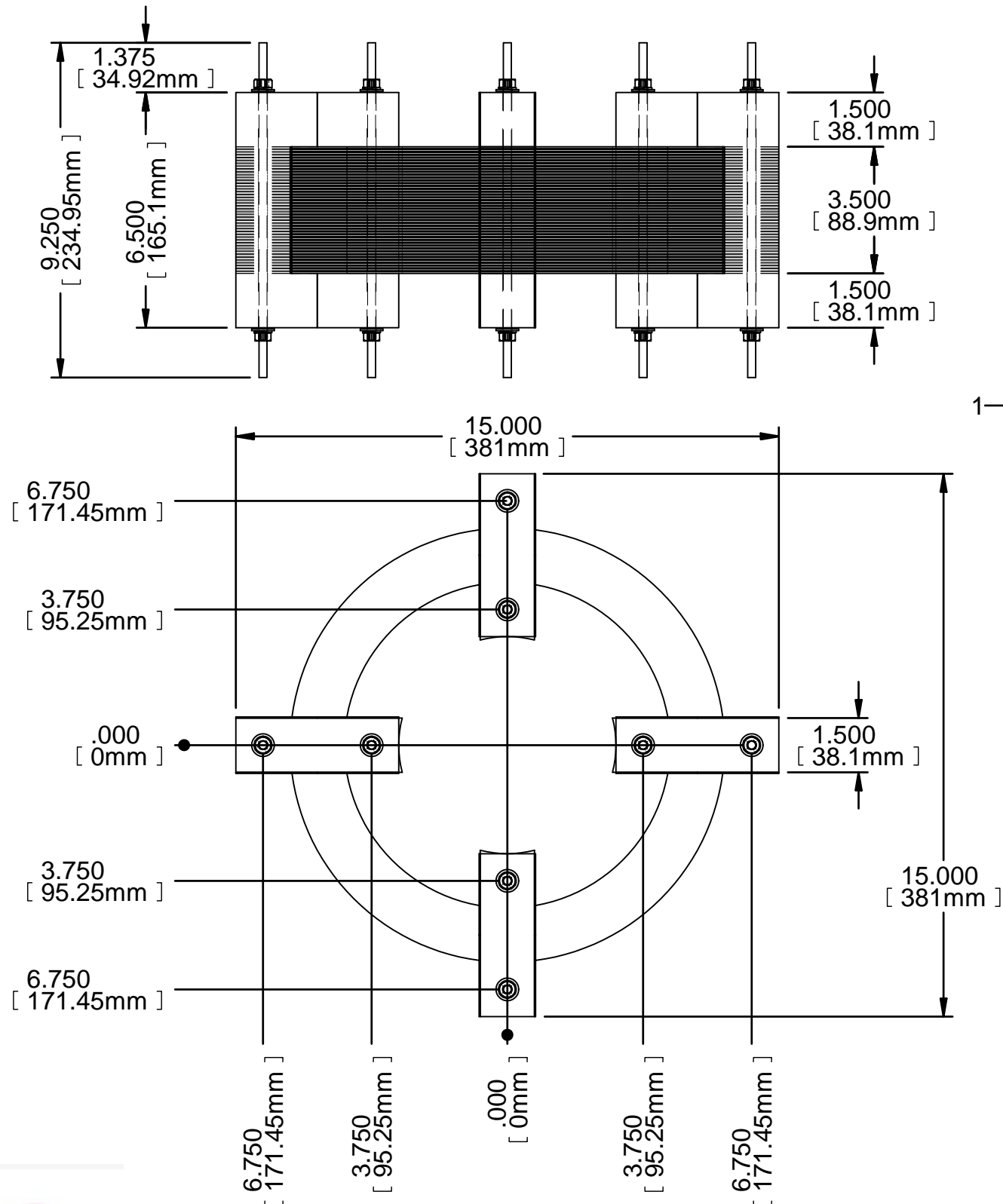

#	P/N	Qty	Description
7	P1006	16	Nut, Hex, 1/4-20, Grade 8
6	P1005	16	Washer, Flat, #1/4
5	P1013	8	Rod, 1/4-20 x 9.25in, Grade 8
4	P1012	8	Insulation, Corner, Nomex, Inner
3	P1011	8	Insulation, Corner, Nomex, Outer
2	P1010	140	Lamination, Stator, 24 Gauge, M19 C5, Electrical Steel
1	P1009	8	Spacer, block, 1-1/2" x 1-1/2" x 4-1/2", Aluminum, 6061-T6

UNLESS OTHERWISE SPECIFIED: XX +/- .020 XXX +/- .005 XXXX +/- .0005 ANGLES +/- 3 DEG. FRACTIONAL TOL: +/- 1/64 ALL DIM'S ARE IN INCHES		COMPUTER FILE LOC: C:\FTW\101\Mech\A1008, Stator, Main, GA.DFT	
		TITLE: Stator Assy 10KW Quantum Energy Generator	
MATERIAL:	DRAWN BY: I. Rivas	DATE: 03.25.15	CHECKED BY: DATE:
FINISH:	DESIGNED BY:	DATE:	APPROVED BY: DATE:
WEIGHT:	Q'TY/ASSY: 1	SCALE: 1 : 4	DWG. No: B-0-101-A1008 REV. 1

PROJ. NAME: 101 P/N: A1008



Quantum Energy Generator
CATSKILLS | NEW YORK



THIS MATERIAL IS OPEN SOURCED BY THE FIX THE WORLD ORGANIZATION.
THIS DOCUMENT MAY BE OPENLY REPRODUCED OR TRANSFERRED WITHOUT LIMIT OR
CONSENT OF THE FIX THE WORLD ORGANIZATION.

Rev.	Description	Date	Init.
1	Updated consent Notice	03.25.15	IR

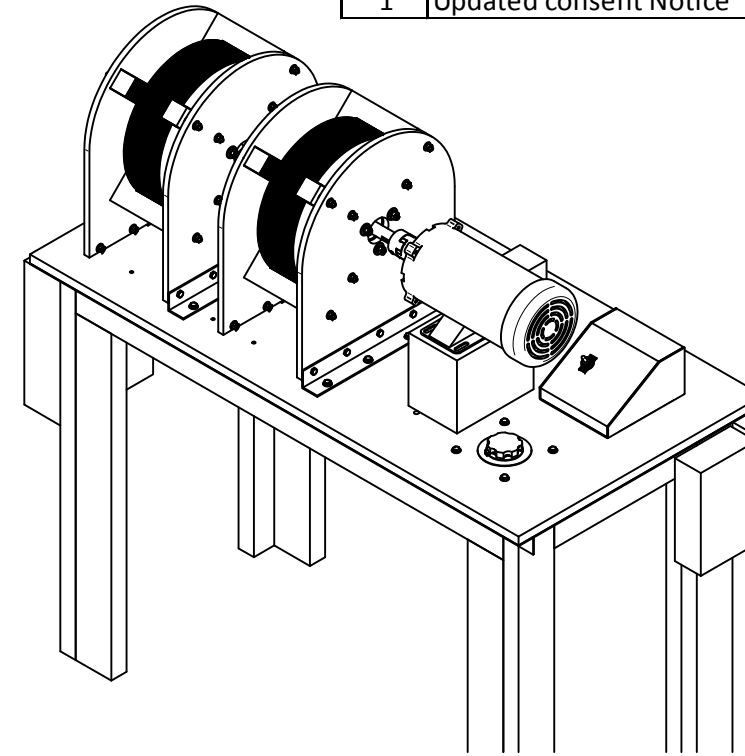
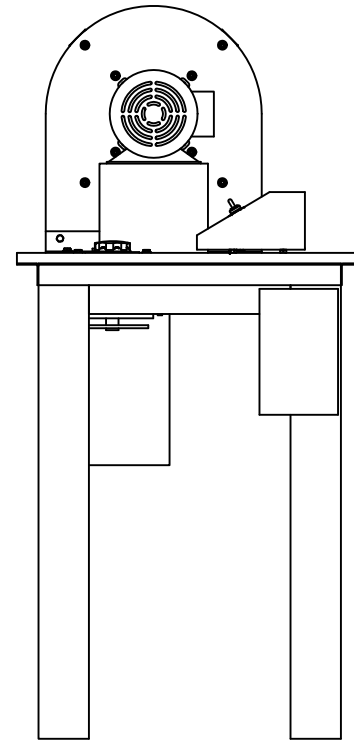
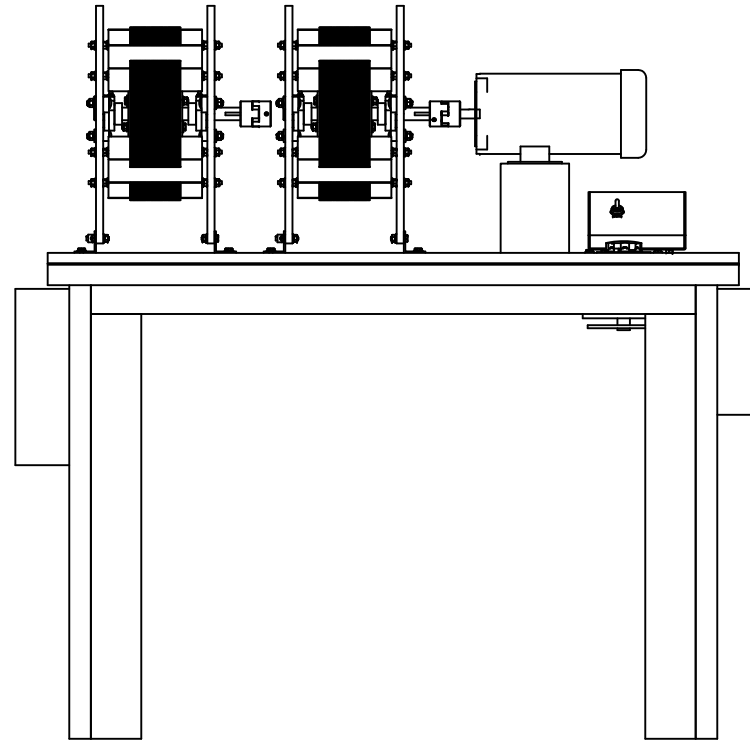

Dual
QEG Core
Mount Option

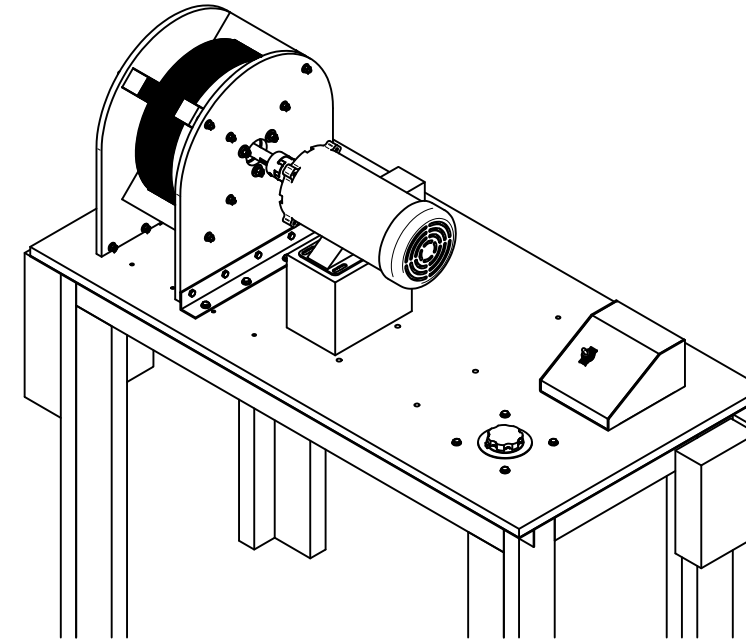
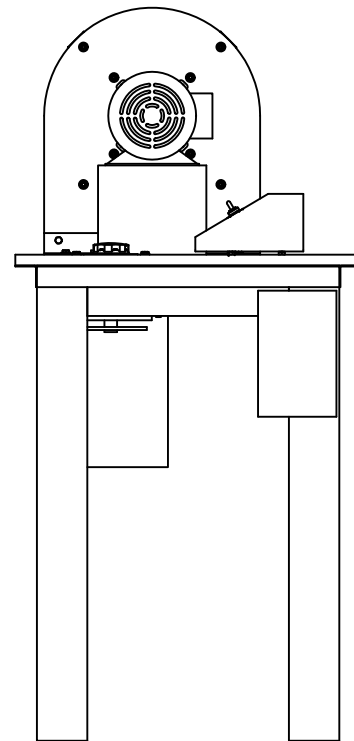
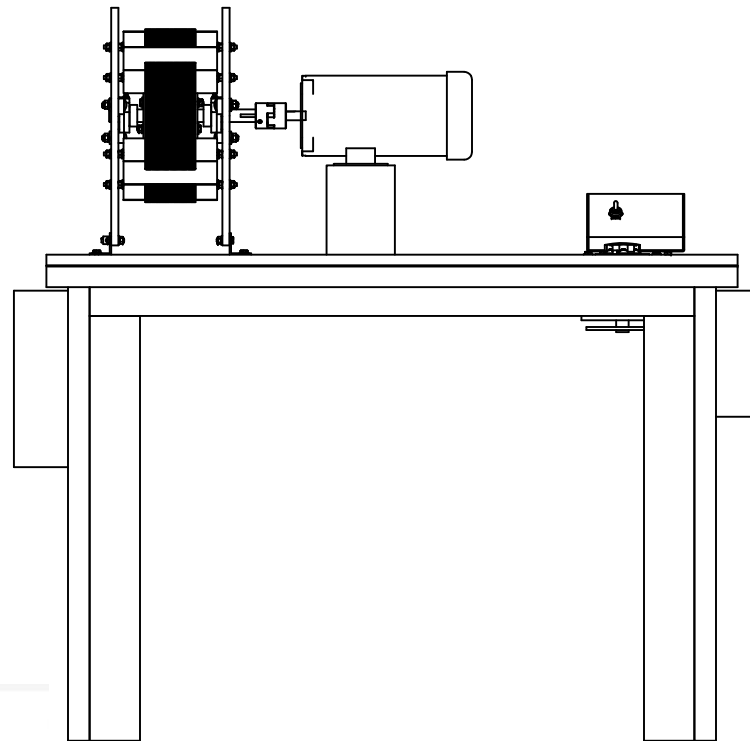

Single
QEG Core
Mount Option



PROJ. NAME:	101	P/N:	A1039
-------------	-----	------	-------

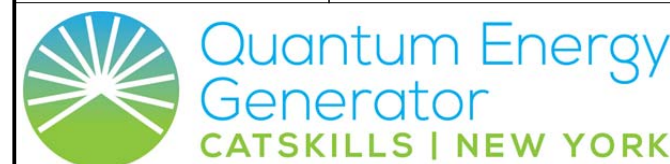

UNLESS OTHERWISE SPECIFIED:		COMPUTER FILE LOC: C:\FTW\101\Mech\A1039, QEG Mount Options.DFT			
XX +/- .020 XXX +/- .005 XXXX +/- .0005 ANGLES +/- 3 DEG. FRACTIONAL TOL: +/- 1/64 ALL DIM'S ARE IN INCHES		TITLE: Single & Dual QEG Core Mount Options			
MATERIAL:	DRAWN BY: Ivan Rivas	DATE: 03.25.15	CHECKED BY:	DATE:	
FINISH:	DESIGNED BY: James Robitaille	DATE:	APPROVED BY:	DATE:	
WEIGHT:	Q'TY/ASS'Y: 1	SCALE: 1 : 10	DWG. No: B-0-101-A1039	REV. 1	

Rev.	Description	Date	Init.
4	Updated consent Notice	03.25.15	IR

THIS MATERIAL IS OPEN SOURCED BY THE FIX THE WORLD ORGANIZATION. THIS DOCUMENT MAY BE OPENLY REPRODUCED OR TRANSFERED WITHOUT LIMIT OR CONSENT OF THE FIX THE WORLD ORGANIZATION.

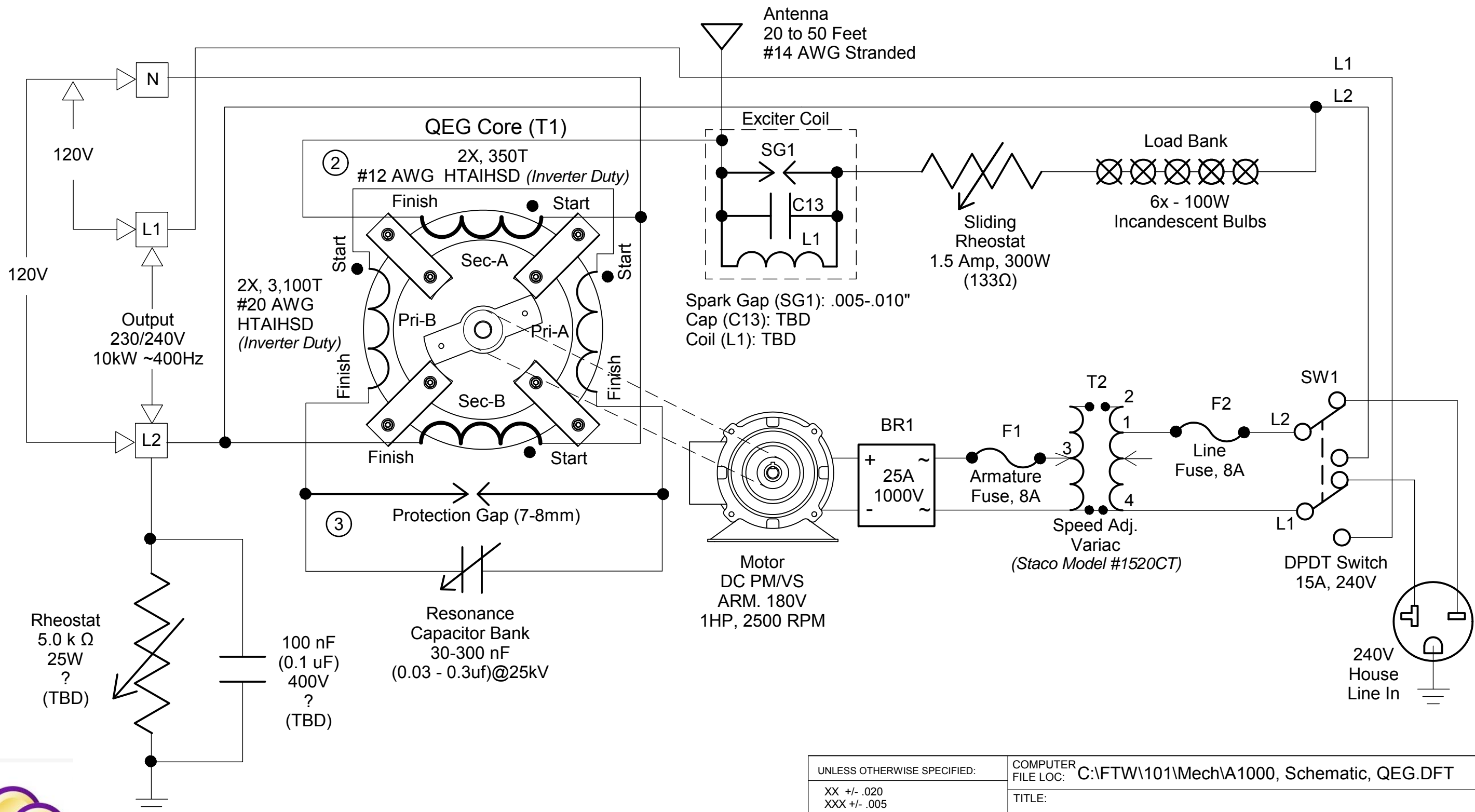

UNLESS OTHERWISE SPECIFIED: XX +/- .020 XXX +/- .005 XXXX +/- .0005 ANGLES +/- 3 DEG. FRACTIONAL TOL: +/- 1/64 ALL DIM'S ARE IN INCHES		COMPUTER FILE LOC: C:\FTW\101\Mech\A1000, Schematic, QEG.DFT	
PROJ. NAME: 101 P/N: A1000		TITLE: QEG Schematic	
MATERIAL:	DRAWN BY: Ivan Rivas	DATE: 03.25.15	CHECKED BY: DATE:
FINISH:	DESIGNED BY: James Robitaille	DATE:	APPROVED BY: DATE:
WEIGHT:	Q'TY/ASSY: 1	SCALE: 1 : 1	DWG. No: B-3-101-A1000 REV. 4

Rev.	Description	Date	Init.
1	Updated consent Notice	03.25.15	IR

THIS MATERIAL IS OPEN SOURCED BY THE FIX THE WORLD ORGANIZATION. THIS DOCUMENT MAY BE OPENLY REPRODUCED OR TRANSFERRED WITHOUT LIMIT OR CONSENT OF THE FIX THE WORLD ORGANIZATION.

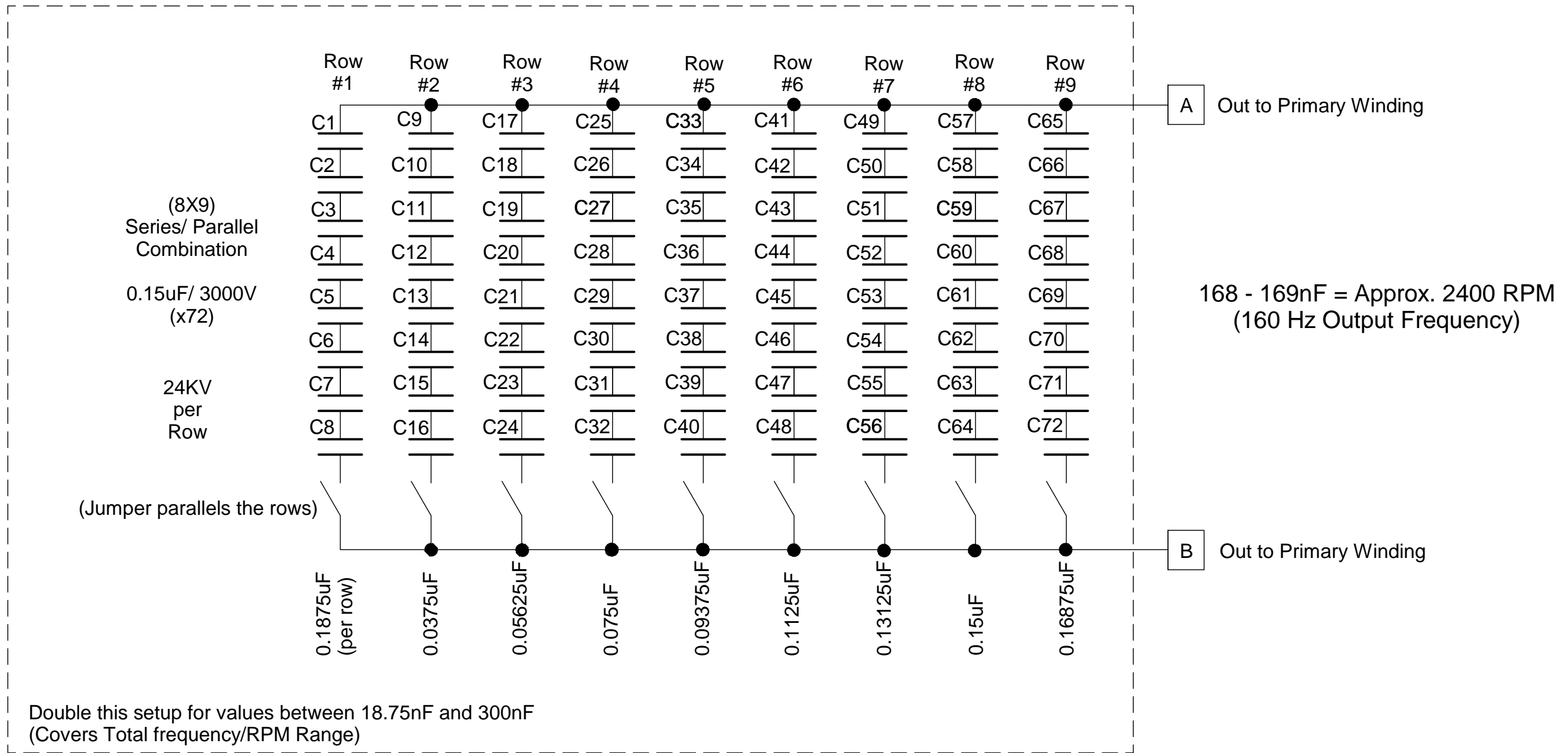

PROJ. NAME:	101	P/N:	A1000
 Quantum Energy Generator CATSKILLS NEW YORK			

UNLESS OTHERWISE SPECIFIED:		COMPUTER FILE LOC: C:\FTW\101\Mech\A1000, Capacitor Load Bank.DFT	
XX +/- .020 XXX +/- .005 XXXX +/- .0005 ANGLES +/- 3 DEG. FRACTIONAL TOL: +/- 1/64 ALL DIM'S ARE IN INCHES		TITLE: Resonance Capacitor Load Bank Suggested for Experimentation	
MATERIAL:	DRAWN BY: Ivan Rivas	DATE: 03.25.15	CHECKED BY: DATE:
FINISH:	DESIGNED BY: James Robitaille	DATE:	APPROVED BY: DATE:
WEIGHT:	Q'TY/ASS'Y: 1	SCALE: 1 : 1	DWG. No: B-5-101-A1000 REV. 1

THIS MATERIAL IS OPEN SOURCED BY THE FIX THE WORLD ORGANIZATION. THIS DOCUMENT MAY BE OPENLY REPRODUCED OR TRANSFERRED WITHOUT LIMIT OR CONSENT OF THE FIX THE WORLD ORGANIZATION.

Rev.	Description	Date	Init.
1	Updated consent Notice	03.25.15	IR

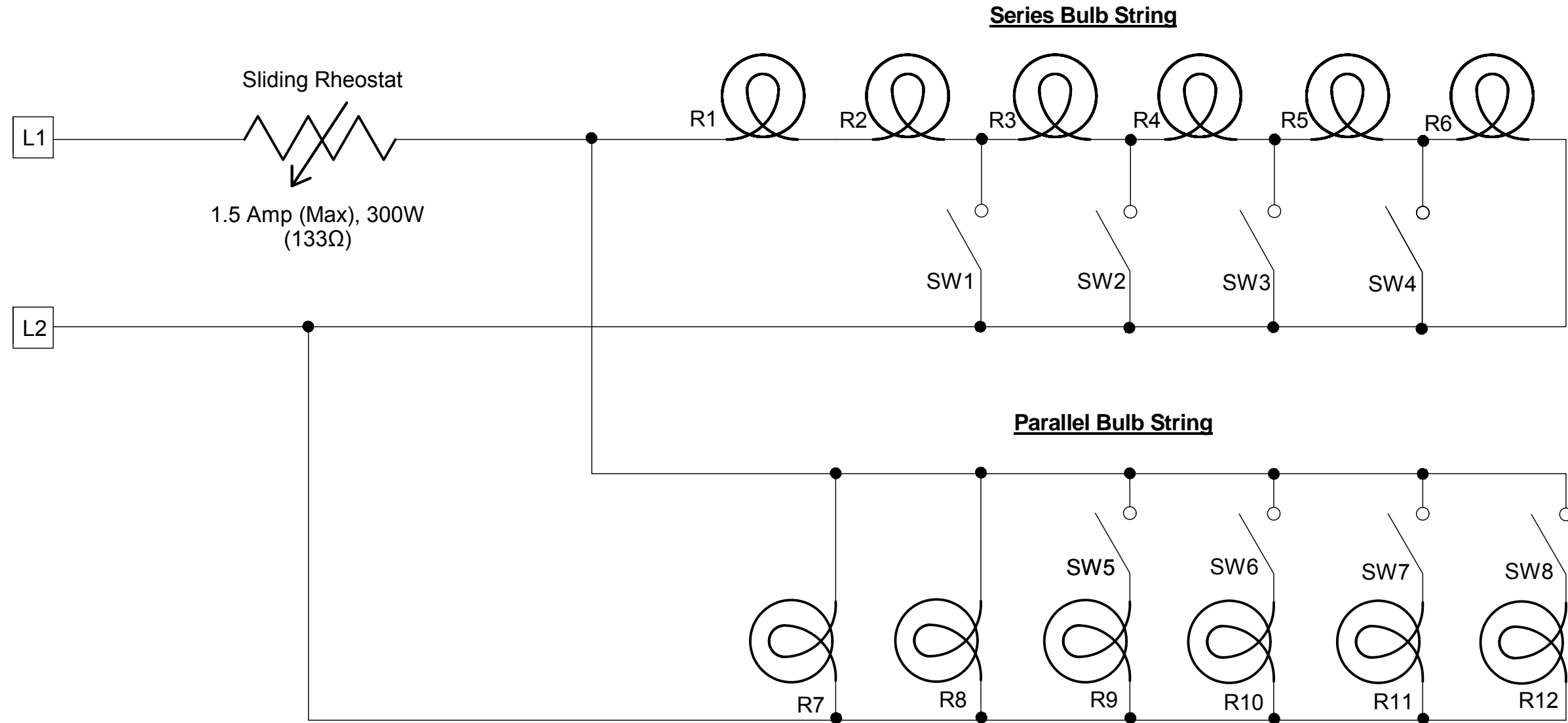

Notes:

1. 12x 72-100W Incandescent Bulbs (Halogen Ok)
2. 120/240V Rated - depending on selected System voltage.
- 3.

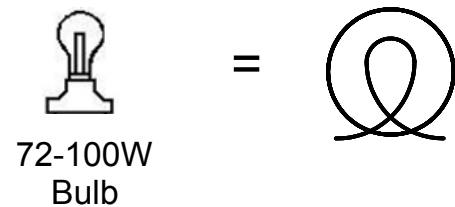

PROJ. NAME:	101	P/N:	A1000
 Quantum Energy Generator CATSKILLS NEW YORK			

UNLESS OTHERWISE SPECIFIED:		COMPUTER FILE LOC: C:\FTW\101\Mech\A1000, Schematic, Load Bank.DFT			
XX +/- .020 XXX +/- .005 XXXX +/- .0005 ANGLES +/- 3 DEG. FRACTIONAL TOL: +/- 1/64 ALL DIM'S ARE IN INCHES		TITLE: Recommended QEG Experimental Load Bank			
MATERIAL:	DRAWN BY: Ivan Rivas	DATE: 03.25.15	CHECKED BY:	DATE:	
FINISH:	DESIGNED BY: James Robitaille	DATE:	APPROVED BY:	DATE:	
WEIGHT:	Q'TY/ASSY: 1	SCALE: 1 : 1	DWG. No: B-5-101-A1000	REV. 1	

Rev.	Description	Date	Init.
2	Updated consent Notice	03.25.15	IR

THIS MATERIAL IS OPEN SOURCED BY THE FIX THE WORLD ORGANIZATION. THIS DOCUMENT MAY BE OPENLY REPRODUCED OR TRANSFERRED WITHOUT LIMIT OR CONSENT OF THE FIX THE WORLD ORGANIZATION.

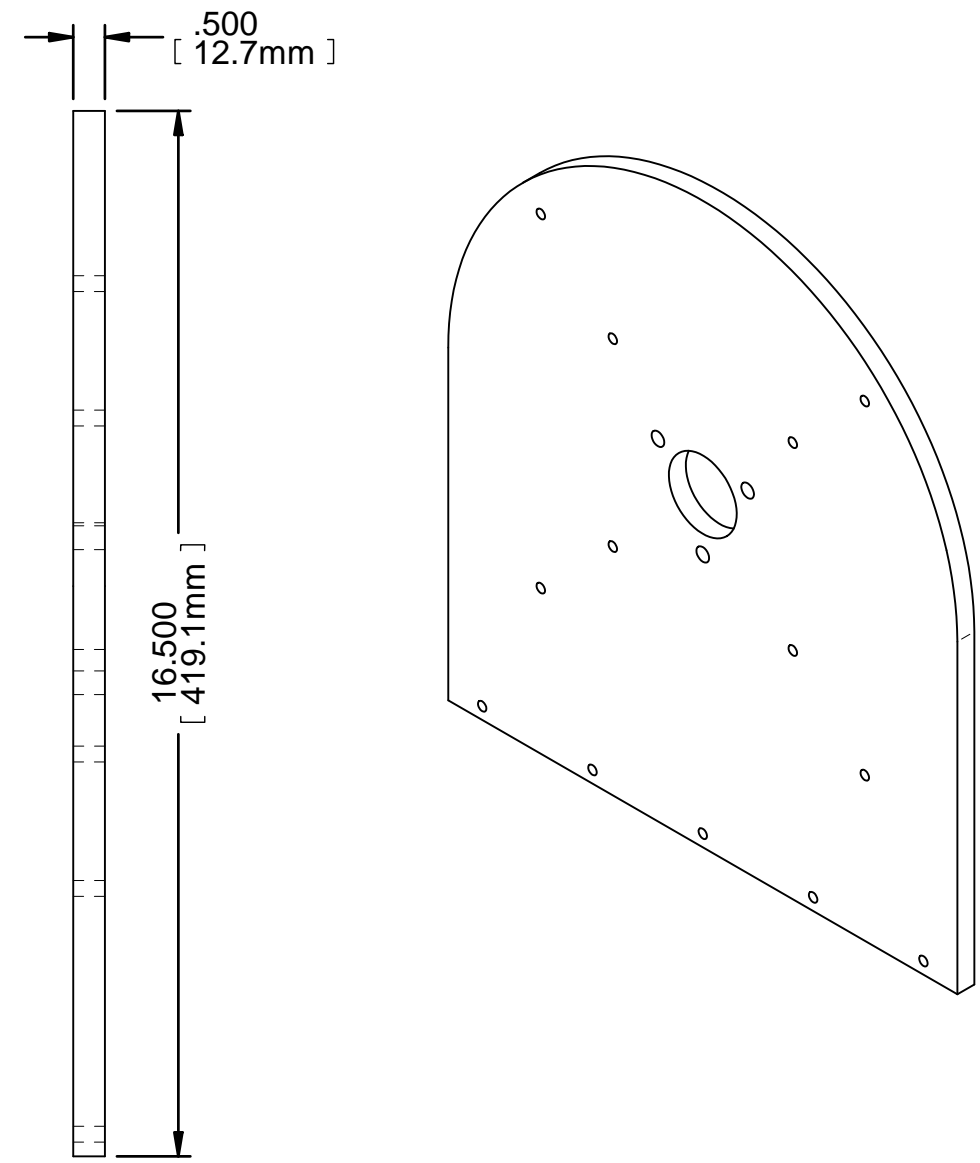
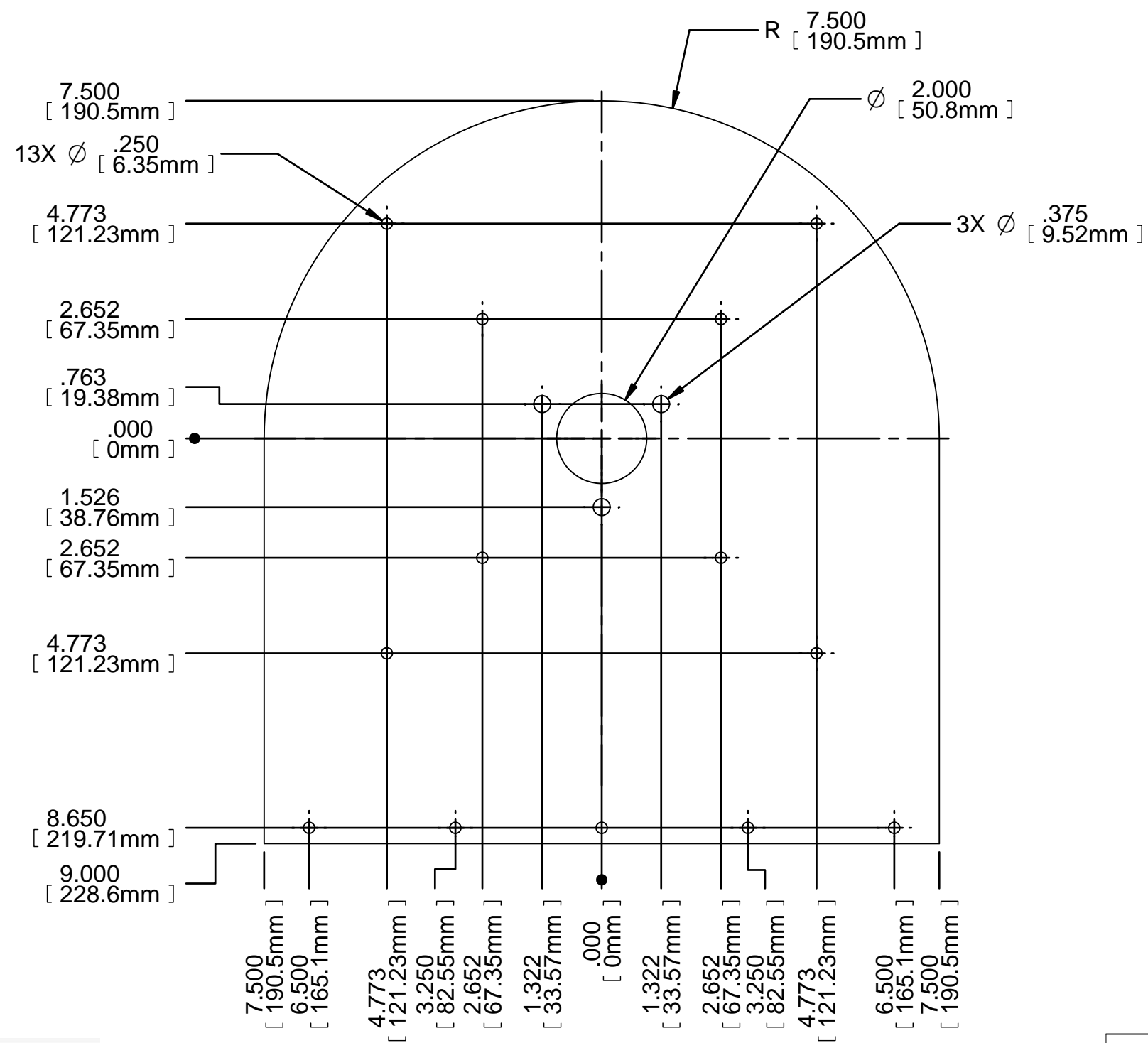

- ① Notes:
1. Material: can use either G10/FR4 or Polycarbonate (Clear plastic).
 2. Used with Flange, Bearing, 3 Bolt, SBTRD205-14G 7/8"



PROJ. NAME: 101 P/N: P1014



UNLESS OTHERWISE SPECIFIED: XX +/- .020 XXX +/- .005 XXXX +/- .0005 ANGLES +/- 3 DEG. FRACTIONAL TOL: +/- 1/64 ALL DIM'S ARE IN INCHES		COMPUTER FILE LOC: C:\FTW\101\Mech\P1014, Plate, End, 15x16.5.DFT	
MATERIAL: See Note		TITLE: Plate, End, 15in x 16.5in x 1/2in Fiberglass, Laminate, Epoxy, Reinforced	
FINISH:	DESIGNED BY: James Robitaille	DATE: 03.25.15	CHECKED BY: DATE:
WEIGHT:	Q'TY/ASS'Y: 2	SCALE: 1 : 3	DWG. No: B-0-101-P1014 REV. 2

THIS MATERIAL IS OPEN SOURCED BY THE FIX THE WORLD ORGANIZATION. THIS DOCUMENT MAY BE OPENLY REPRODUCED OR TRANSFERED WITHOUT LIMIT OR CONSENT OF THE FIX THE WORLD ORGANIZATION.

Rev.	Description	Date	Init.
1	Updated consent Notice	03.25.15	IR

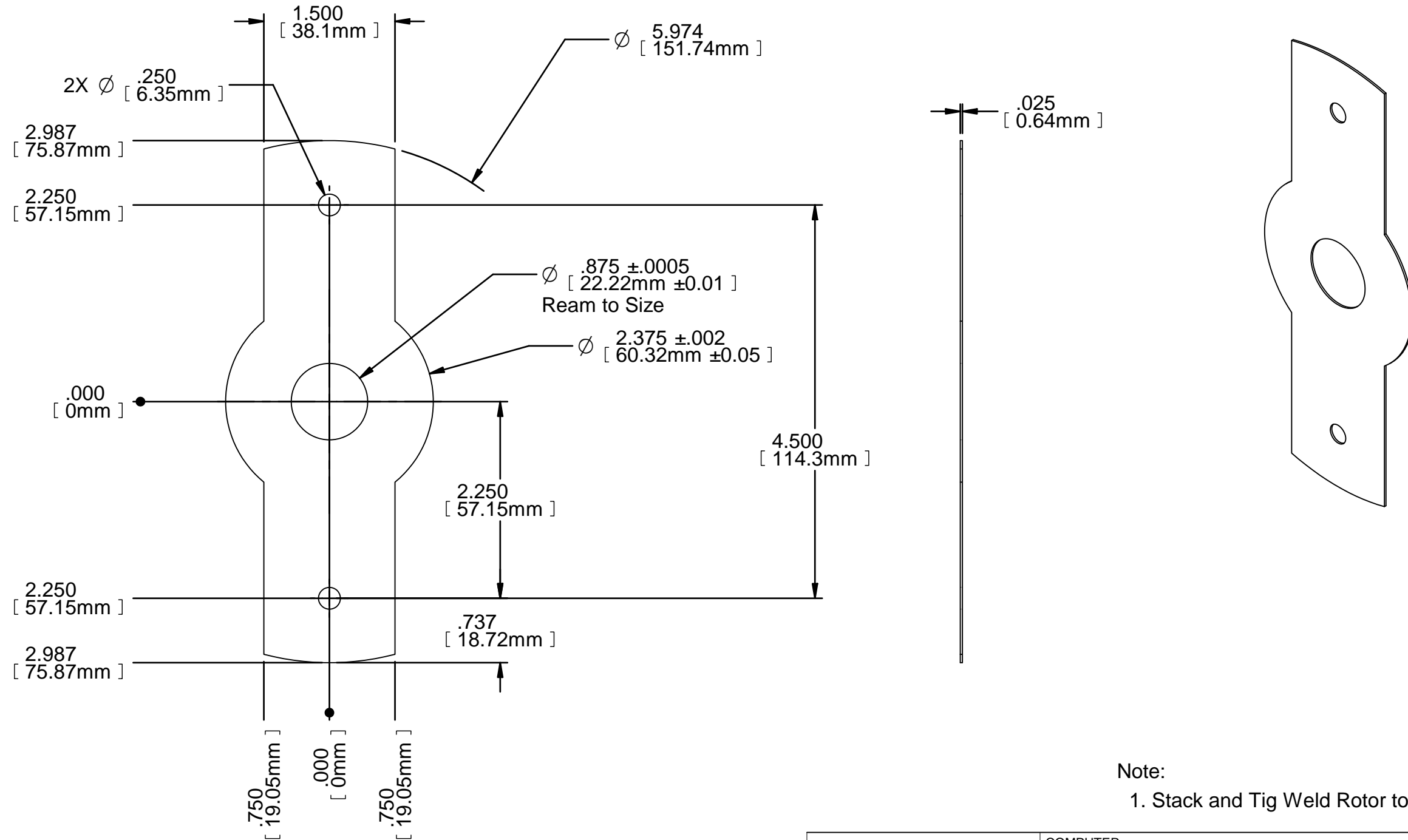

Note:
1. Stack and Tig Weld Rotor to a Length: 3.5" +/- .025



PROJ. NAME:	101	P/N:	P1002
 Quantum Energy Generator CATSKILLS NEW YORK			

UNLESS OTHERWISE SPECIFIED:		COMPUTER FILE LOC: C:\FTW\101\Mech\P1002, Rotor.DFT			
XX +/- .020 XXX +/- .005 XXXX +/- .0005 ANGLES +/- 3 DEG. FRACTIONAL TOL: +/- 1/64 ALL DIM'S ARE IN INCHES		TITLE: Rotor Generator Magnetic Core			
MATERIAL:	24GA/ M19C5	DRAWN BY:	Ivan Rivas	DATE:	03.25.15
FINISH:		DESIGNED BY:	James Robitaille	APPROVED BY:	
WEIGHT:		Q'TY/ASS'Y:	140	SCALE:	3 : 4
			DWG. No:	B-0-101-P1002	REV. 1

THIS MATERIAL IS OPEN SOURCED BY THE FIX THE WORLD ORGANIZATION. THIS DOCUMENT MAY BE OPENLY REPRODUCED OR TRANSFERED WITHOUT LIMIT OR CONSENT OF THE FIX THE WORLD ORGANIZATION.

Rev.	Description	Date	Init.
3	Updated consent Notice	03.25.15	IR

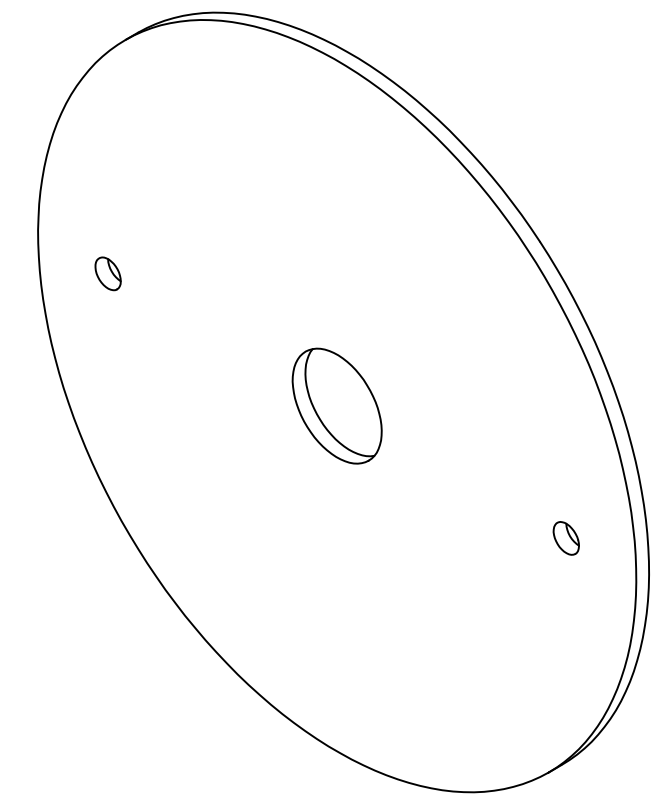
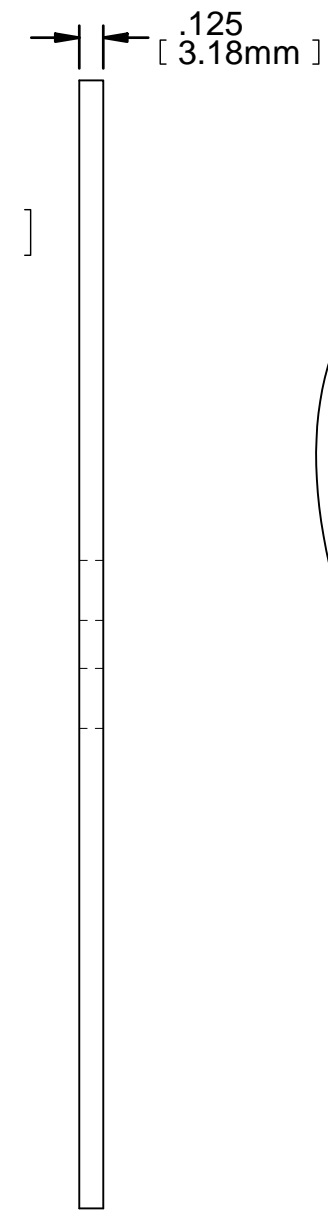
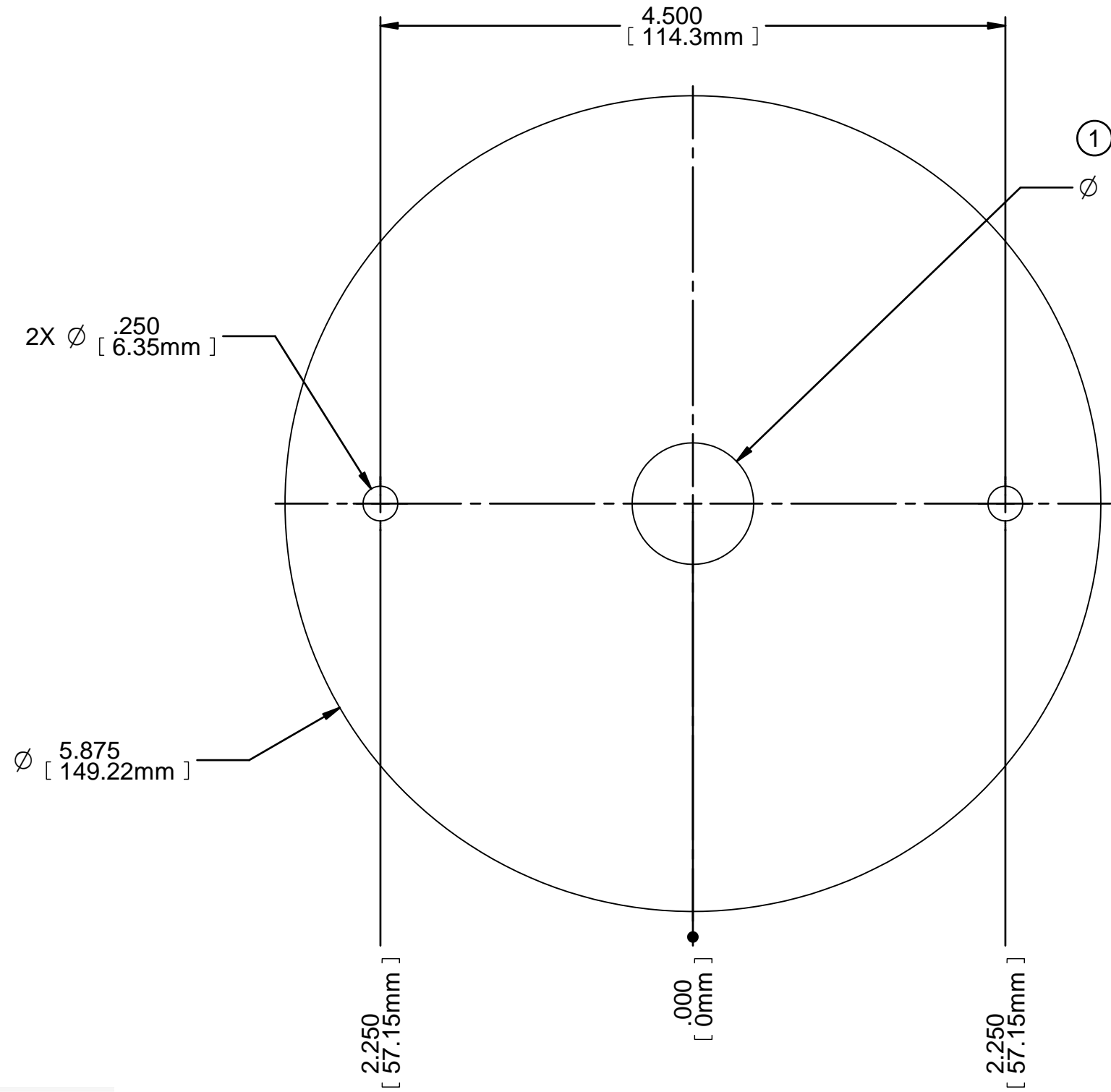

② Note:
1. Material: can use either G10/FR4 or Polycarbonate (Clear plastic).



PROJ. NAME:	101	P/N:	P1001
 Quantum Energy Generator CATSKILLS NEW YORK			

UNLESS OTHERWISE SPECIFIED:		COMPUTER FILE LOC: C:\FTW\101\Mech\P1001, Plate, Rotor.DFT			
XX +/- .020 XXX +/- .005 XXXX +/- .0005 ANGLES +/- 3 DEG. FRACTIONAL TOL: +/- 1/64 ALL DIM'S ARE IN INCHES		TITLE: Shroud, 1/8in Thk x 5.875in Dia. Fiberglass, Laminate, Epoxy, Reinforced			
MATERIAL:	See Note	DRAWN BY:	DATE:	CHECKED BY:	DATE:
FINISH:		DESIGNED BY:	DATE:	APPROVED BY:	DATE:
WEIGHT:		Q'TY/ASS'Y:	SCALE:	DWG. No:	REV.
		2	1 : 1	B-0-101-P1001	3

THIS MATERIAL IS OPEN SOURCED BY THE FIX THE WORLD ORGANIZATION. THIS DOCUMENT MAY BE OPENLY REPRODUCED OR TRANSFERRED WITHOUT LIMIT OR CONSENT OF THE FIX THE WORLD ORGANIZATION.

Rev.	Description	Date	Init.
1	Updated consent Notice	03.25.15	IR

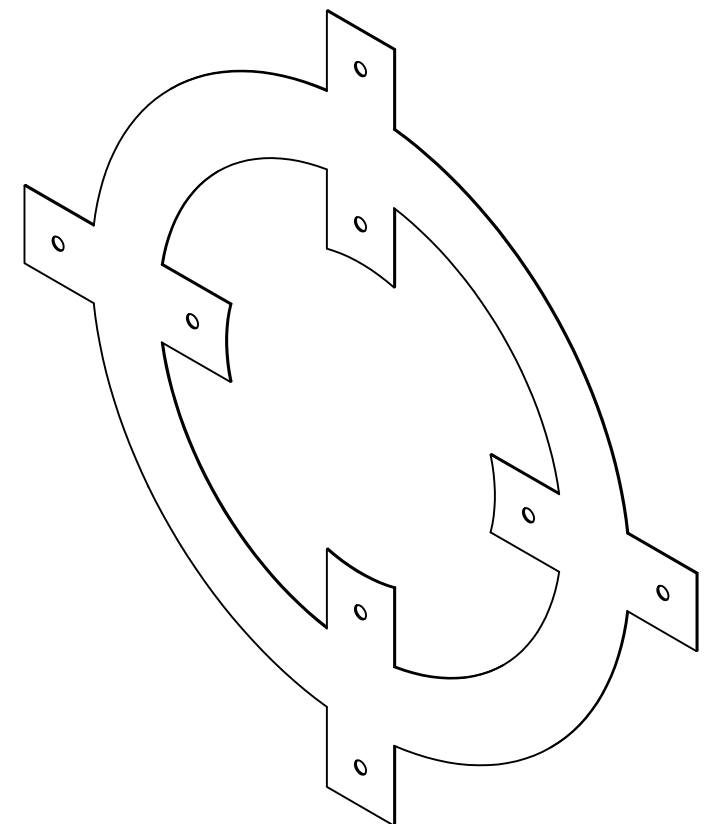
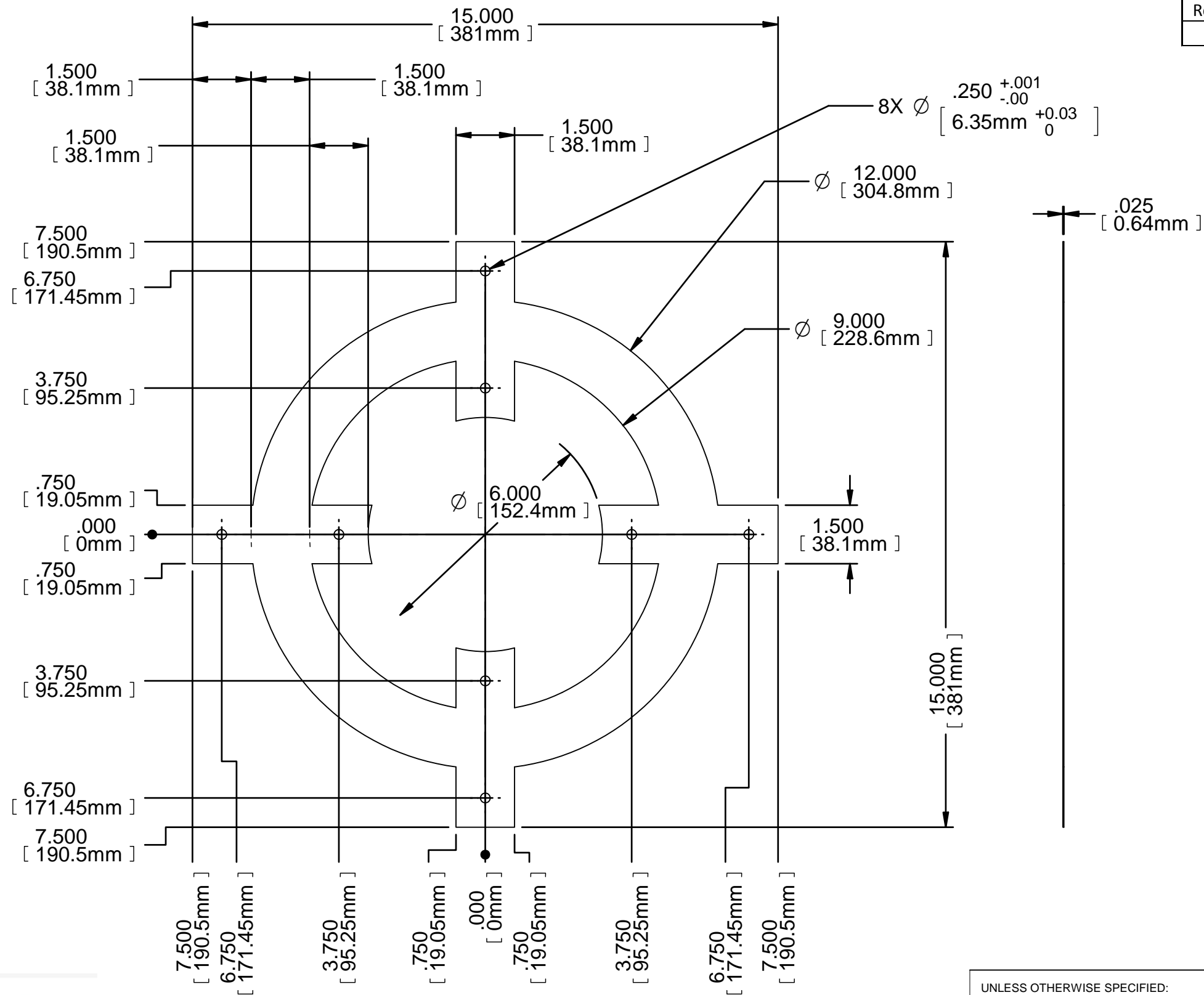

Note:

1. Stack and Tig Weld Stator to a Length: 3.5" +/- .025

PROJ. NAME:	101	P/N:	P1010
-------------	-----	------	-------



UNLESS OTHERWISE SPECIFIED:		COMPUTER FILE LOC: C:\FTW\101\Mech\P1010, Stator, pg1.DFT			
XX +/- .020 XXX +/- .005 XXXX +/- .0005 ANGLES +/- 3 DEG. FRACTIONAL TOL: +/- 1/64 ALL DIM'S ARE IN INCHES		TITLE: Stator Generator Magnetic Core			
MATERIAL:	24GA/ M19C5	DRAWN BY:	Ivan Rivas	DATE:	03.25.15
FINISH:		DESIGNED BY:	James Robitaille	APPROVED BY:	
WEIGHT:		Q'TY/ASS'Y:	140	SCALE:	1 : 3
			DWG. No:	B-0-101-P1010	REV. 1



Fix the World
A "NEW PARADIGM" BUSINESS MODEL

Rev.	Description	Date	Init.
1	Updated consent Notice	03.25.15	IR

THIS MATERIAL IS OPEN SOURCED BY THE FIX THE WORLD ORGANIZATION. THIS DOCUMENT MAY BE OPENLY REPRODUCED OR TRANSFERED WITHOUT LIMIT OR CONSENT OF THE FIX THE WORLD ORGANIZATION.

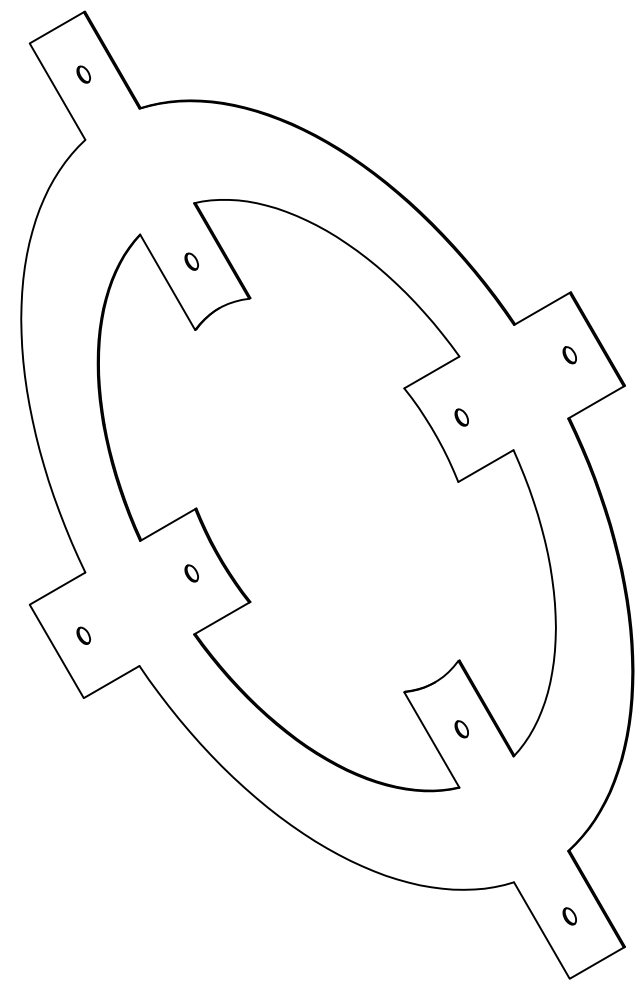
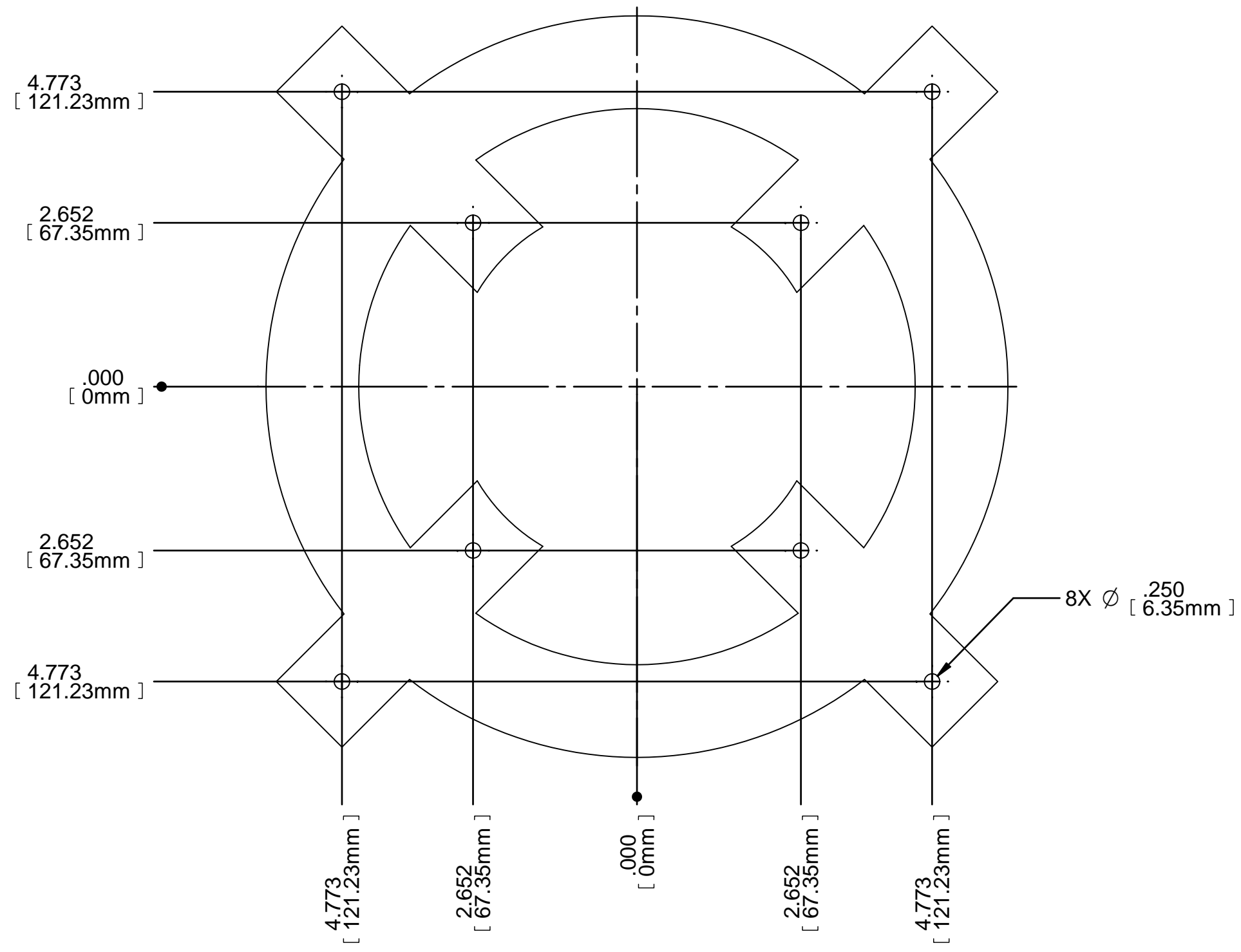

PROJ. NAME:	101	P/N:	P1010
 Quantum Energy Generator CATSKILLS NEW YORK			

UNLESS OTHERWISE SPECIFIED:		COMPUTER FILE LOC: C:\FTW\101\Mech\P1010, Stator, pg2.DFT			
XX +/- .020 XXX +/- .005 XXXX +/- .0005 ANGLES +/- 3 DEG. FRACTIONAL TOL: +/- 1/64 ALL DIM'S ARE IN INCHES		TITLE: Stator at 45 Deg., Mount Position Generator Magnectic Core			
MATERIAL:	24GA/ M19C5	DRAWN BY:	Ivan Rivas	DATE:	03.25.15
FINISH:		DESIGNED BY:	James Robitaille	APPROVED BY:	
WEIGHT:		Q'TY/ASSY:	140	SCALE:	1 : 2
			DWG. No:	B-1-101-P1010	REV. 1



SHAFT DETAIL

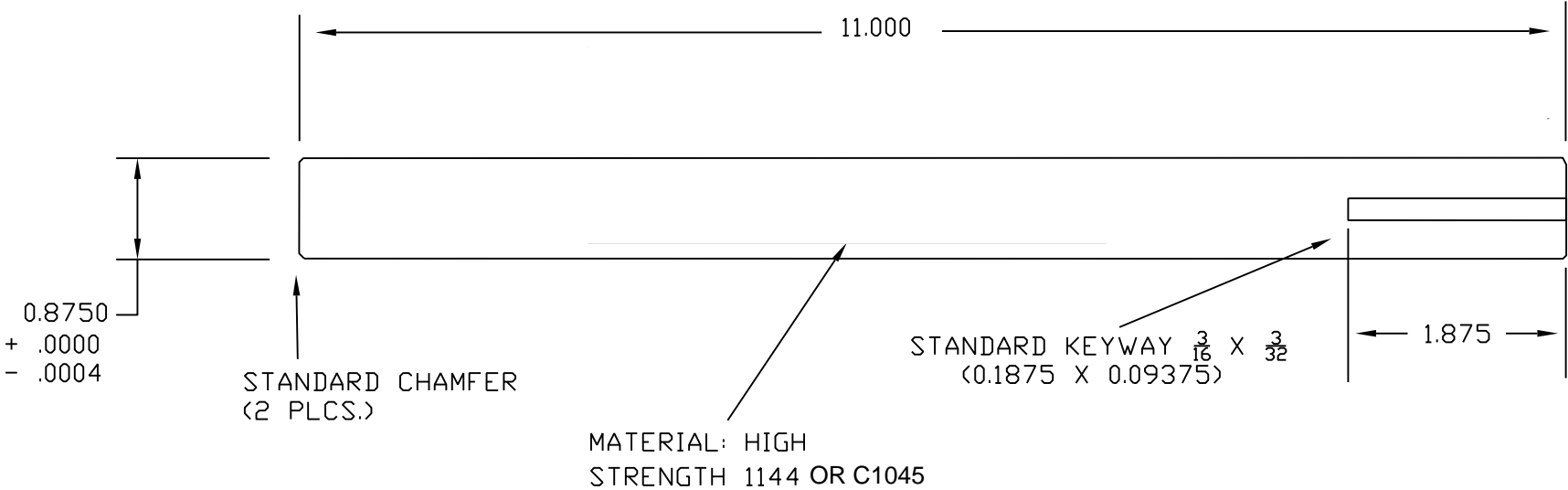

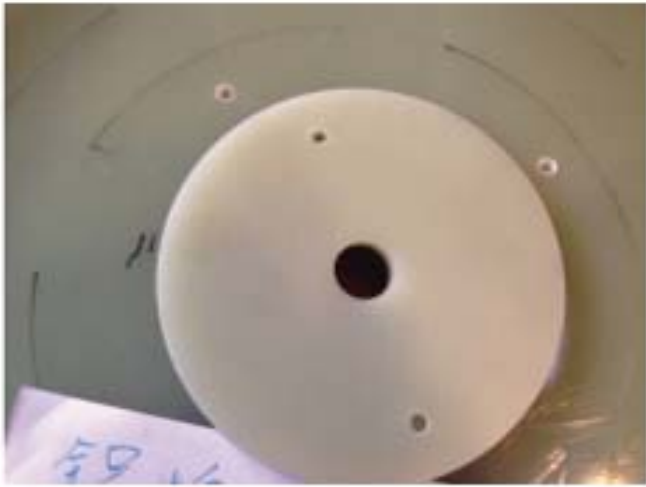

Shroud (2 needed)



Shaft



Stator



Spacers



DIY Toroidal Winder



End Plate (2 needed)



Stator, Rotor, Shaft

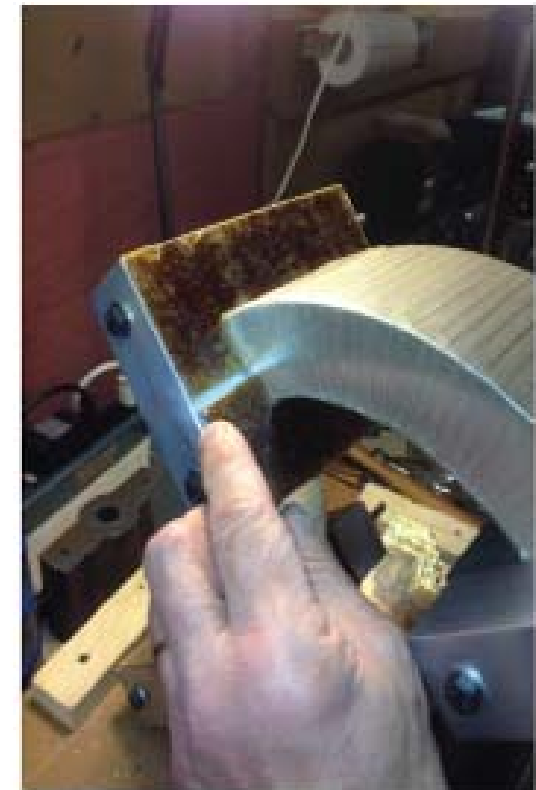

Installing cut mica plates



Installing front end plate



Rotor



Installing outer wrap on core



12 AWG Magnet Wire



Ironhorse Brand Drive Motor



20 AWG Magnet Wire



Resonance Capacitors



Rocker Switches



Bridge Rectifier



(2) 3 bolt flange bearing



(2) 4 bolt flange bearing

OR



Base/Platform



Finished Bore Pulley



Bushed Pulley

OR



8 Ft. Grounding Rod

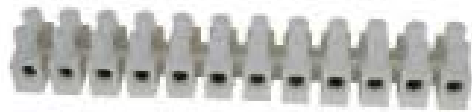

Euro Barrier Strip



Core on winding machine



Motor Controller (optional)



Motor Controller Box (optional)

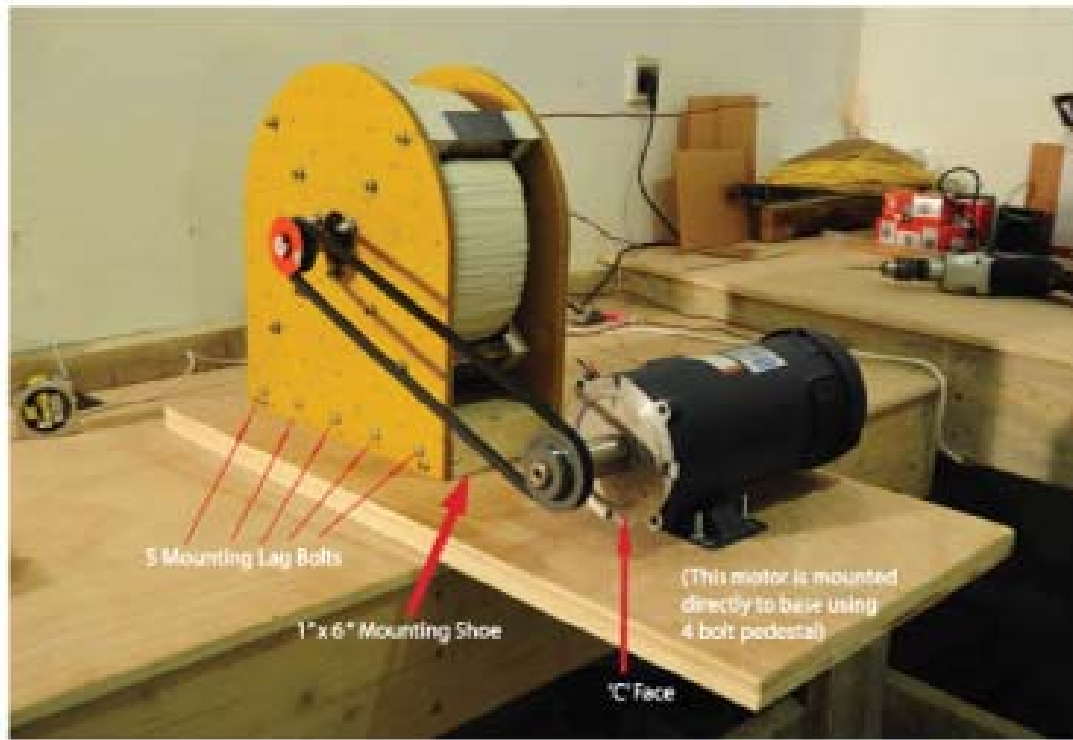

Mica fixed and variable capacitors



Mica Tape



Bonding Compound/Activator



Optional filter cap for motor



Exciter Coil with Litz wire



Load Bank Example

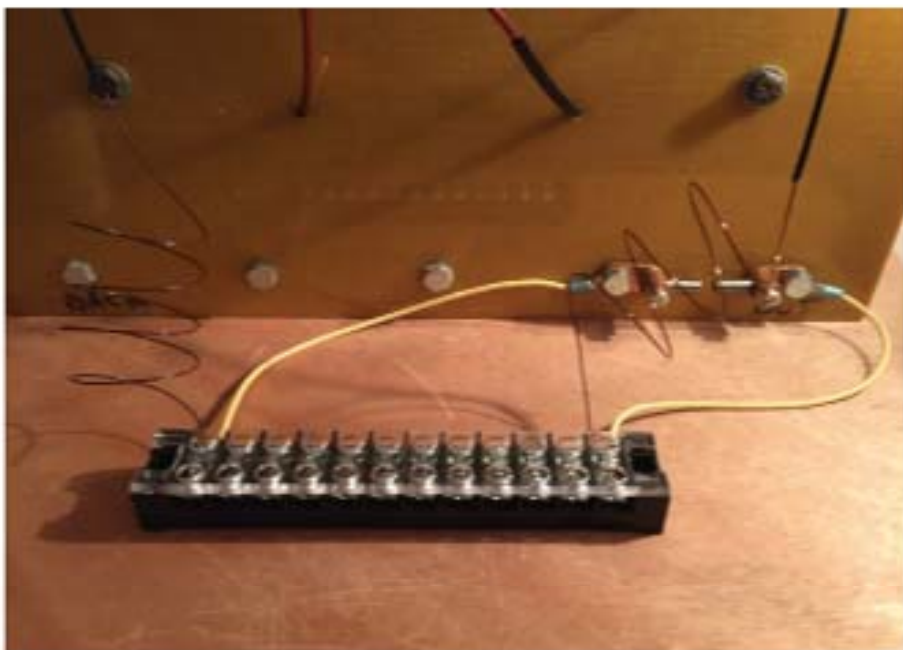

Protection Gap Wiring

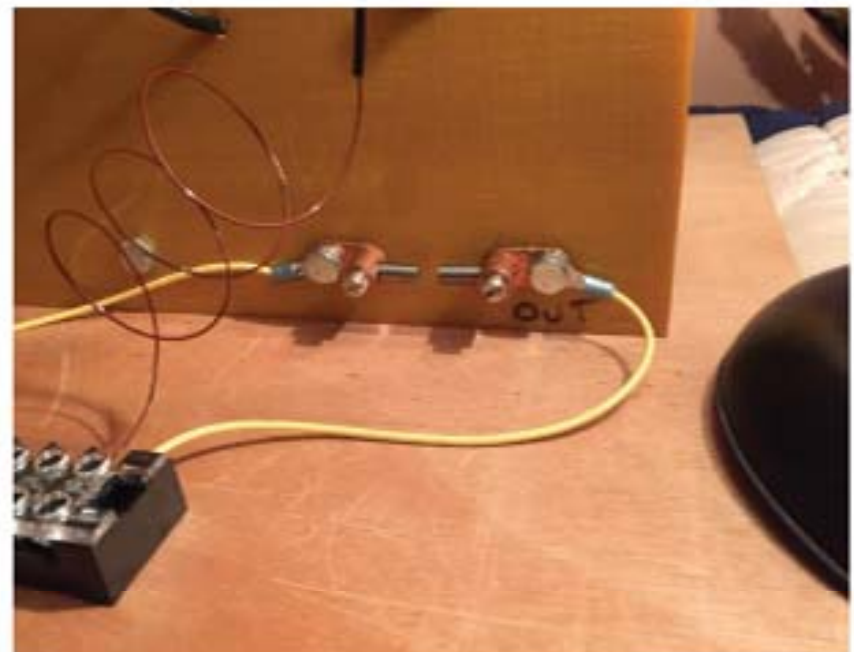

Protection Gap Mounting

NOMEX corner insulation
used here

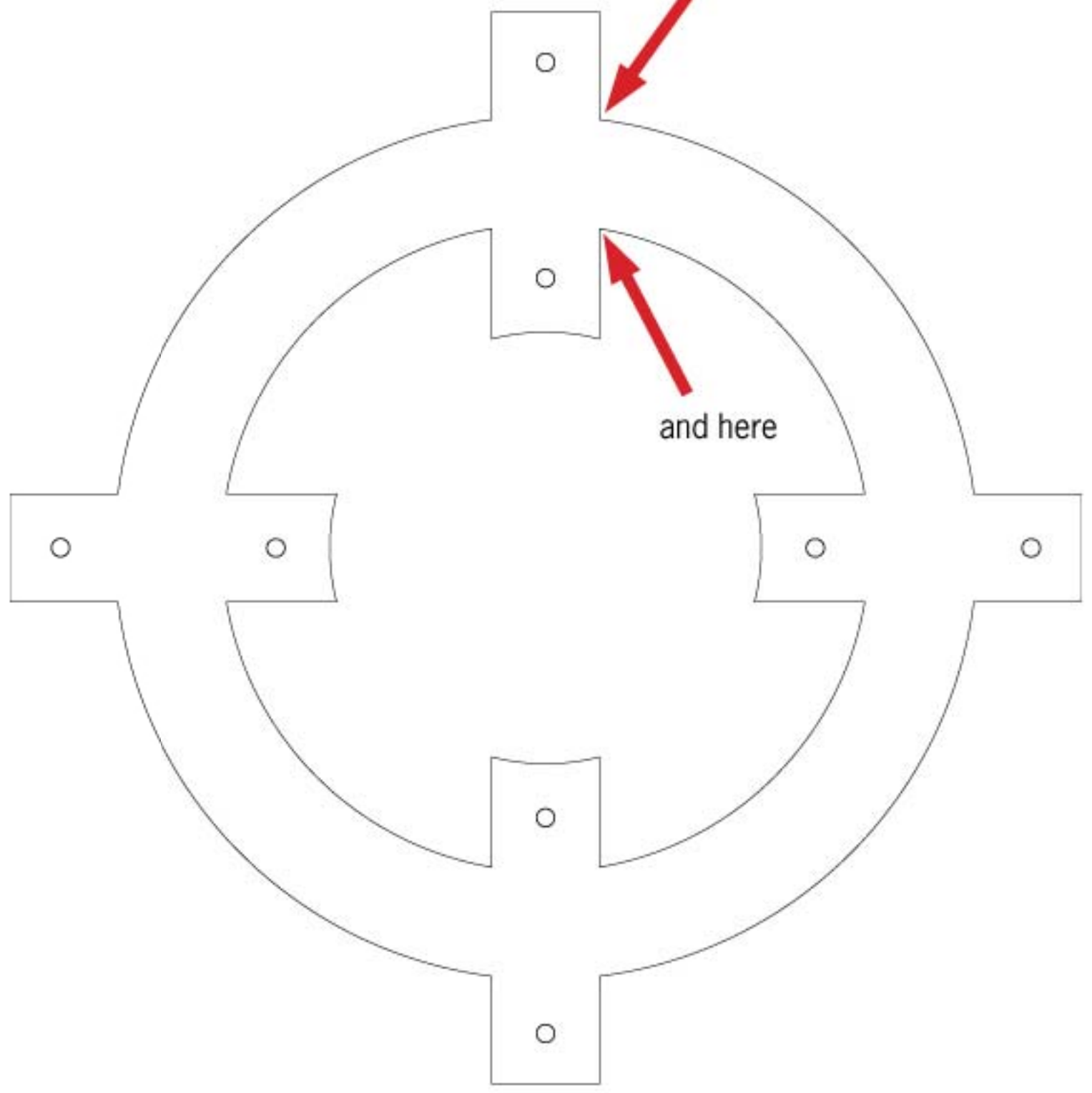

and here

NOMEX CORNER INSULATION:

These are pieces (16 per core) of DuPont Nomex Type 418 high-voltage insulating paper, .015 to .025" thickness, used in the corner between winding area of the core and the faces of each pole piece. This is used to keep the wire from falling down to the bare steel in the corner between mica insulating plates and mica tape wrap. This is provided by Torelco when ordering a fully-processed core.

NOMEX® TYPE 418 AND 419

NOMEX® Type 418 is designed for high-voltage applications, including motor conductor and coil wrap, transformer ground and layer insulation. It is a calendered product with high inherent dielectric strength (30 to 40 kV/mm), which can be readily impregnated with varnishes where this is desirable. NOMEX® Type 418 is available in 5 thicknesses, from 0.08 to 0.36 mm (3 to 14 mil). This calendered blend of aramid and mica offers increased voltage endurance over NOMEX® Type 410 when subjected to corona attack.

NOMEX® Type 419 is the uncalendered precursor of NOMEX® Type 418, and is available in two thicknesses, 0.18 and 0.33 mm (7 and 13 mil). NOMEX® Type 419 is used in applications which take advantage of the lower density (0.5) which allows improved conformability and saturability.

Electrical properties

The typical electrical property values for NOMEX® Type 418 and NOMEX® Type 419 papers are shown in Table I. The AC Rapid Rise dielectric strength data of Table I, representing voltage stress levels, withstood 10 to 20 seconds at a frequency of 60 Hz. These values differ from long-term strength potential. DuPont recommends that continuous stresses in transformers not exceed 3.2 kV/mm (80 V/mil) to minimize the risk of partial discharges (corona). The Full Wave Impulse dielectric strength data of Table I were generated on flat sheets, such as in layer and barrier applications. The geometry of the system has an effect on the actual impulse strength values of the material.

TECHNICAL DATA SHEET

The dielectric strength data are typical values and not recommended for design purposes. Design values can be supplied upon request.

Please note:

The properties in this data sheet are typical, or average values and should not be used as specification limits. Unless otherwise noted, all properties were measured in air under "standard" conditions (in equilibrium at 23°C, 50% relative humidity). Note that, like other products of papermaking technology, NOMEX® papers have somewhat different properties in the papermaking machine direction (MD) compared to the cross direction (XD). In some applications it may be necessary to orient the paper in the optimum direction to obtain its maximum potential performance.

Table I – **TYPICAL ELECTRICAL PROPERTIES**

Type		418					419	
		3 0.08	5 0.13	8 0.20	10 0.25	14 0.36	7 0.18	13 0.33
Dielectric Strength								
AC rapid rise ¹⁾	(V/mil)	770	890	1020	965	920	395	370
	(kV/mm)	30.3	35.0	40.2	38.0	36.2	15.6	14.6
Full wave impulse ²⁾	(V/mil)	1600	1600	1600	1700	1500	650	650
	(kV/mm)	63	63	63	67	59	26	26
Dielectric constant ³⁾	50% RH	2.9	3.6	4.0	4.1	3.4	2.0	2.0
	Dry ⁴⁾	2.3	2.5	2.5	2.5	2.1	1.4	1.5
Dissipation factor ³⁾	50% RH	130	120	140	140	150	140	130
	at 60 Hz (x10 ⁻⁴)	Dry ⁴⁾	6	6	6	6	5	11
Volume resistivity ⁵⁾	50% RH	(10) ¹³	(10) ¹³	(10) ¹³	(10) ¹³	(10) ¹⁴	(10) ¹³	(10) ¹³
	(ohm.cm)	Dry ⁴⁾	(10) ¹⁶	(10) ¹⁶	(10) ¹⁶	(10) ¹⁶	(10) ¹⁵	(10) ¹⁶
Surface resistivity ⁵⁾	50% RH	(10) ¹¹	(10) ¹²	(10) ¹²	(10) ¹²	(10) ¹³	(10) ¹³	(10) ¹³
	(ohm/square)	Dry ⁴⁾	(10) ¹⁴	(10) ¹⁵	(10) ¹⁵	(10) ¹⁵	(10) ¹⁵	(10) ¹⁶

¹⁾ ASTM D-149 using 50mm (2 inches) electrodes, rapid rise; corresponds with IEC 243-1 subclause 9.1, except for electrodes set-up of 50mm (2 inches)

²⁾ ASTM D-3426

³⁾ ASTM D-150

⁴⁾ Values measured at 23°C after one hour drying at 120°C

⁵⁾ ASTM D-257

QEG MAGNET WIRE DATA -**PRIMARY WINDINGS - 3100T (X2)**

STANDARD AWG SIZE	SQUARE MILLIMETER	NON-STANDARD IEC METRIC SIZE
#20	0.518591	0.8128

INSULATING FILM TYPEHTAIHSD (200° C, POLYESTER POLYAMIDE/IMIDE, **INVERTER DUTY**, NEMA MW35-C)**REQUIRED LENGTH/WEIGHT**

1 FOOT/TURN (NOMINAL) = 6,200 FEET [1,889.76 M]

@ 3.217 POUNDS / 1,000 FEET = 6.200 X 3.217 = 19.95 POUNDS [9.05 kg]

RECOMMENDED PURCHASE:21 POUNDS [9.53 kg]
or 6,300 FEET [1,920.24 M]**NOMINAL COATED WIRE DIAMETER**

INCH	MILLIMETER
0.0339	0.8611

SECONDARY WINDINGS - 350T (X2)

STANDARD AWG SIZE	SQUARE MILLIMETER	NON-STANDARD IEC METRIC SIZE
#12	3.306339	2.0523

INSULATING FILM TYPEHTAIHSD (200° C, POLYESTER POLYAMIDE/IMIDE, **INVERTER DUTY**, NEMA MW35-C)**REQUIRED LENGTH/WEIGHT**

1 FOOT/TURN (NOMINAL) = 700 FEET [213.36 M]

@ 20.13 POUNDS / 1,000 FEET = .700 X 20.13 = 14.1 POUNDS [6.4 kg]

RECOMMENDED PURCHASE:15 POUNDS [6.8 kg]
or 750 FEET [228.6 M]**NOMINAL COATED WIRE DIAMETER**

INCH	MILLIMETER
0.0838	2.1285

END PANELS WIRING

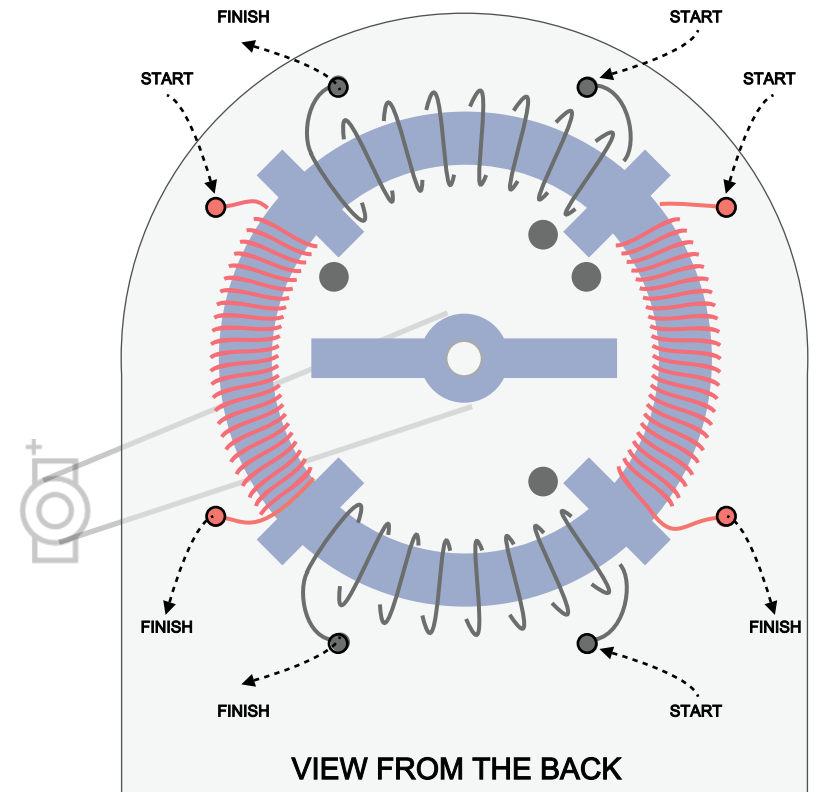
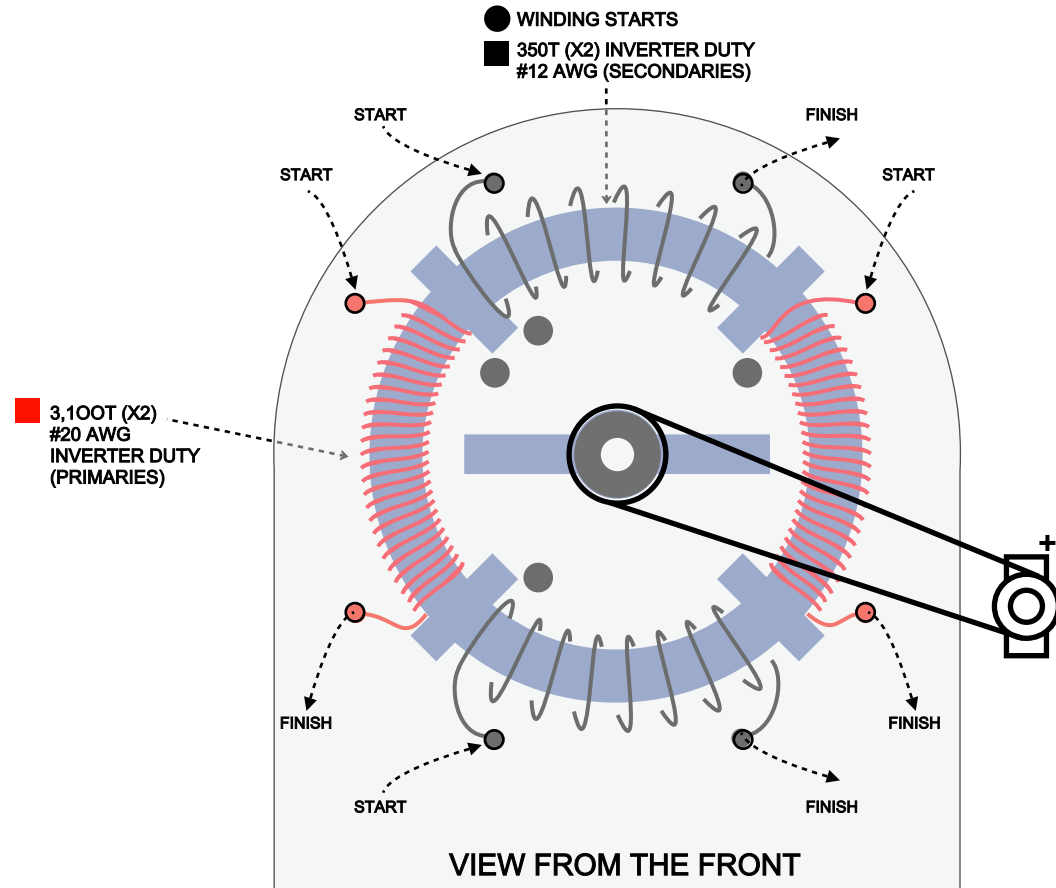

design by Tivon Rivers
www.spacevisuals.com

QEG SCHEMATIC
7 FEB 2015

1 2 3 4 5 6 7 8

A
B
C
D
E
F
G
H

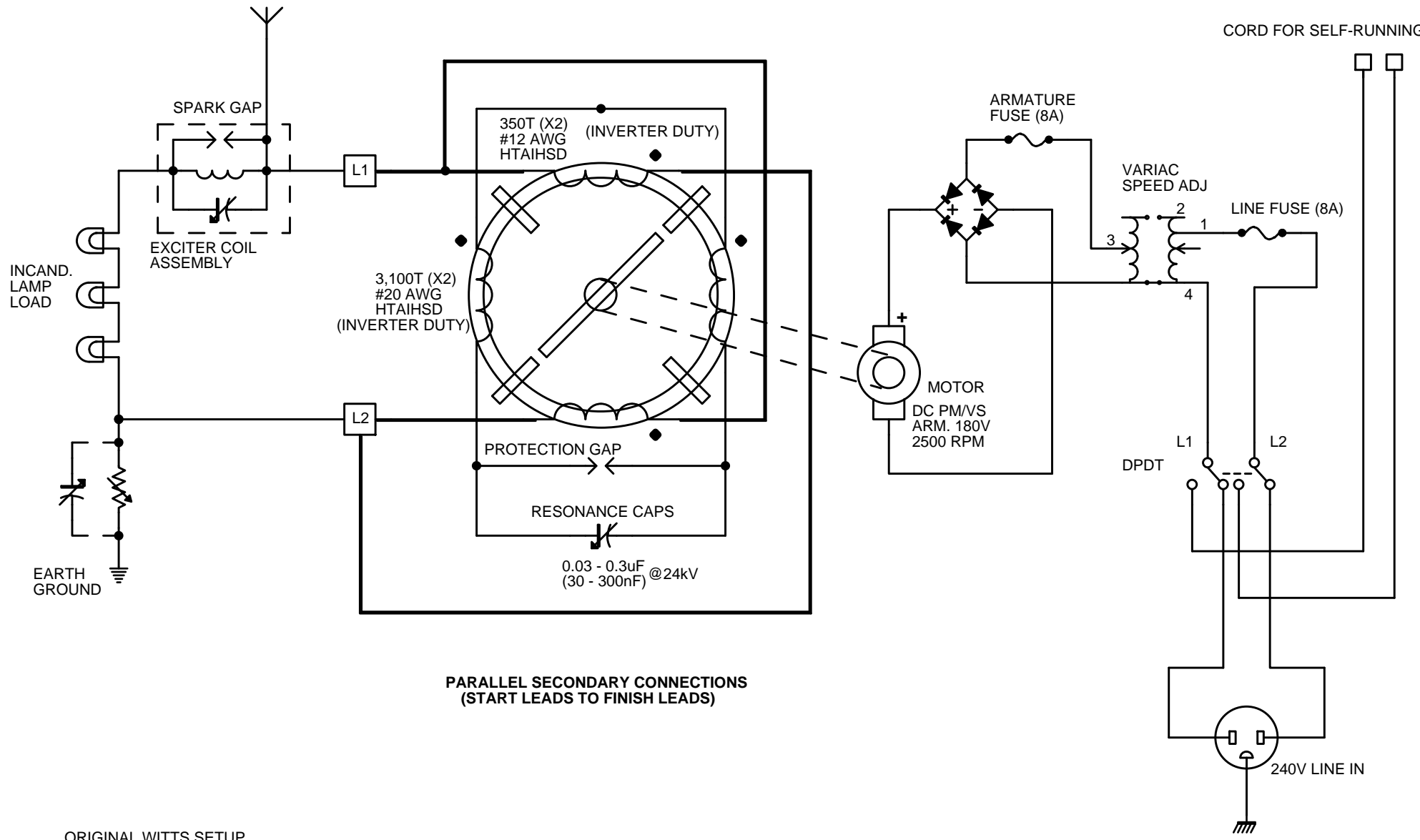

ORIGINAL WITTS SETUP

TANK CAPACITOR MIX AND MATCH

Discrete Value 2000V Rated	Series Multiplier	Final Value		Total Value of (n) Parallel Rows (nF)				
		uF	nF	X8	X9	X10	X11	X12
0.1uF	X 12	0.008333	8.3	66.4	74.7	83	91.3	99.6
0.15uF	X 12	0.0125	12.5	100	112.5	125	137.5	150
0.2uF	X 12	0.016666	16.6	132.8	149.4	166	182.6	199.2
0.25uF	X 12	0.020833	20.83	166.64	187.47	208.3	229.13	249.96
0.3uF	X 12	0.025	25	200	225	250	275	300
0.35uF	X 12	0.029166	29.16	233.28	262.44	291.6	320.76	349.92
0.4uF	X 12	0.033333	33.3	266.4	299.7	333	366.3	399.6
0.45	X 12	0.0375	37.5	300	337.5	375	412.5	450
0.5uF	X 12	0.041666	41.6	332.8	374.4	416	457.6	499.2
0.55uF	X 12	0.045833	45.83	366.64	412.47	458.3	504.13	549.96
0.6uF	X 12	0.05	50	400	450	500	550	600
0.65uF	X 12	0.054166	54.16	433.28	487.44	541.6	595.76	649.92
0.7uF	X 12	0.058333	58.3	466.4	524.7	583	641.3	699.6
0.75uF	X 12	0.0625	62.5	500	562.5	625	687.5	750
0.8uF	X 12	0.066666	66.6	532.8	599.4	666	732.6	799.2
0.85uF	X 12	0.070833	70.83	566.64	637.47	708.3	779.13	849.96
0.9uF	X 12	0.075	75	600	675	750	825	900
0.95uF	X 12	0.079166	79.16	633.28	712.44	791.6	870.76	949.92
1.0uF	X 12	0.083333	83.3	666.4	749.7	833	916.3	999.6
1.2uF	X 12	0.1	100	800	900	1000	1100	1200
1.5uF	X 12	0.125	125	1000	1125	1250	1375	1500
2.0uF	X 12	0.166666	166	1328	1494	1660	1826	1992
2.2uF	X 12	0.183333	183.3	1466.4	1649.7	1833	2016.3	2199.6
2.5uF	X 12	0.208333	208.3	1666.4	1874.7	2083	2291.3	2499.6
3.0uF	X12	0.25	250	2000	2250	2500	2750	3000
3000V Rated				X8	X9	X10	X11	X12
0.1uF	X8	0.0125	12.5	100	112.5	125	137.5	150
0.15uF	X8	0.01875	18.75	150	168.75	187.5	206.25	225
0.2uF	X8	0.025	25	200	225	250	275	300
0.25uF	X8	0.03125	31.25	250	281.25	312.5	343.75	375
0.3uF	X8	0.0375	37.5	300	337.5	375	412.5	450
0.35uF	X8	0.04375	43.75	350	393.75	437.5	481.25	525
0.4uF	X8	0.05	50	400	450	500	550	600
0.45	X8	0.05625	56.25	450	506.25	562.5	618.75	675
0.5uF	X8	0.0625	62.5	500	562.5	625	687.5	750
0.55uF	X8	0.06875	68.75	550	618.75	687.5	756.25	825
0.6uF	X8	0.075	75	600	675	750	825	900
0.65uF	X8	0.08125	81.25	650	731.25	812.5	893.75	975
0.7uF	X8	0.0875	87.5	700	787.5	875	962.5	1050
0.75uF	X8	0.09375	93.75	750	843.75	937.5	1031.25	1125
0.8uF	X8	0.1	100	800	900	1000	1100	1200
0.85uF	X8	0.10625	106.25	850	956.25	1062.5	1168.75	1275
0.9uF	X8	0.1125	112.5	900	1012.5	1125	1237.5	1350
0.95uF	X8	0.11875	118.75	950	1068.75	1187.5	1306.25	1425
1.0uF	X8	0.125	125	1000	1125	1250	1375	1500
1.2uF	X8	0.15	150	1200	1350	1500	1650	1800
1.5uF	X8	0.1875	187.5	1500	1687.5	1875	2062.5	2250
2.0uF	X8	0.25	250	2000	2250	2500	2750	3000
2.2uF	X8	0.275	275	2200	2475	2750	3025	3300
2.5uF	X8	0.3125	312.5	2500	2812.5	3125	3437.5	3750
3.0uF	X8	0.375	375	3000	3375	3750	4125	4500

QEG SUGGESTED TOOLS & EQUIPMENT LIST

(updated 18-Jan-2015)

- (1) Tabletop Drill Press
- (1) Cordless Drill
- (1) Drill Bit Set (assorted sizes Metric/Imperial)
- (2) Extra Long ¼" (.250") [6.35mm] Drill Bits (general purpose)
- (1) Benchtop Grinder
- (1) Medium Bench Vise
- (1) Heat Gun
- (1) Heat Shrink Tubing Set (assorted sizes)
- (1) Good Quality 6" Dial or Digital Calipers
- (1) Small Grease Gun w/Hi-Temp Grease
- (1) Small, Good Quality ¼" & 3/8" Drive Metric & Imperial Socket set
- (1) ¼" Drive Extension (6")
- (1) Small Set ¼" Drive Imperial Allen Key Bits
- (1) Small Set ¼" Drive Metric Allen Key Bits
- (1) Good Quality General Purpose Terminal Crimping Tool
- (1) Good Electronics Soldering Station w/Spare Tips, Electronic Solder (Rosin Core)
- (1) Industrial Size Soldering Gun w/Spare Tips, 180 – 300 Watt
- (1) Deburring Tool
- (1) Hot Glue Gun w/Glue Sticks
- (1) Small Bottle Acetone (or Alcohol)
- (1) Hacksaw w/Blades (General Purpose)
- (1) Good Quality Small Flush Cutters for Electronics Work
- (1) Assorted Hand Tools (rubber mallet, hammer, needle nose pliers, screwdrivers, etc.)

QEG GENERAL WIRING ITEMS LIST

- (1) Short Reel 15M (50 feet) 1.5mm 3-Conductor Cordage (Extension Cord Reel)
- (1) Short Reel 15M (50 feet) 2.5mm 3-Conductor Cordage (Extension Cord Reel)
- (Assortment) Ring & Spade Terminals
- (1) 8 foot [2.44M] Copper or Copper Clad Grounding Rod w/Clamp
- (1 Roll) Electrical Tape
- (1) Small Fluorescent Tube (15 Watt)
- (10) Standard Surface Mount Light Bulb Sockets
- (6) 100 Watt, 240 Volt Incandescent Light Bulbs
- (6) 100 Watt, 120 Volt Incandescent Light Bulbs

QEG NUTS AND BOLTS (HARDWARE) LIST

- (4) M8 (5/16") x 60mm (2-1/4") Carriage Bolts (Motor Mounting)
- (12 pcs. each) M8 (5/16") Hex Nuts, Flat Washers, Lockwashers

- (8) M8 (5/16") x 40mm (1-1/2") Carriage Bolts (Bearing Mounting)
- (8) M10 (3/8") x 40mm (1-1/2") Carriage Bolts (Alternate Bearing Mounting)
- (8 pcs. each) M10 (3/8") Hex Nuts, Flat Washers, Lockwashers
- (10) M6 (1/4") x 65mm (2-1/2") Lag Screws (Assembled Core to Mounting Shoe)
- (10 pcs. each) M6 (1/4") Flat Washers, Lockwashers

QEG INSTRUMENTATION (TEST EQUIPMENT) LIST

- (1) Digital Storage Oscilloscope. Minimum 4-Channel, 100MHz, Example: Tektronix Model TDS2014 (100MHz), or TDS 2024B (200mHz)
- (1) 1X Scope Probe
- (2) 10X Scope Probes
- (1) 100X Scope Probe
- (1) 1000X (High Voltage) Probe for Scope/DMM, 40kV (example: Fluke Model 80K-40)
- (1) Female Banana plug to BNC adapter (for above 1000X High Voltage Probe if needed for scope)
- (1) Digital Signal/Function Generator w/output cable. (Minimum 5MHz. 20MHz would be better)
- (2) Clamp-On Oscilloscope Current Probes, Minimum 0-40 Amp, AC/DC
- (1) Clamp-On Digital Multimeter & Probes
- (2) General Purpose DMMs & Probes (Capacitor function is helpful)
- (1) Portable Relative RF Field Strength Meter w/antenna (Ideal Range: 500kHz – 200MHz or higher). Example: Coaxial Dynamics Model 7600 (1 MHz - 1GHz) or Model 7601 (1 MHz - 3 GHz)
- (2) Good Quality LCR Meters (get 2 different brands. Inductance range must be over 20 Henries)
- (1) Plug-In Power Usage Monitor/Wattmeter (Digital Multifunction Power Monitor. Buy for use in your specific Country).
- (1) Portable Digital Laser Tachometer

QEG 'SWEET SPOT' TEST

Test #	Image #	Power in W	Speed	Cap nf	Vrms	Amp x001	freq	Pwr out
1	3277	690	1733	332.0	163	17.6	116	286.88
2	3278	700	1751	325.5	162	15.5	115	251.1
3	3279	710	1760	322.0	166	17.7	116	293.82
4	3280	700	1788	312.5	171	18	119	307.8
5	3281	705	1807	306.4	155	16.2	120	251.1
6	3282	705	1815	303.5	160	17	120	272
7	3283	703	1842	294.8	160	17	123	272
8	3284	700	1860	289.3	155	16.5	124	255.75
9	3285	705	1869	286.7	160	17	125	272
10	3286	700	1896	278.8	160	17	126	272
11	3287	700	1913	274.0	145	16	127	232
12	3288	700	1922	271.5	160	17	128	272
13	3289	700	1948	264.4	155	17	129	263.5
14	3290	710	1965	260.0	163	17	130	277.1
15	3291	695	1973	257.9	160	16.3	132	260.8
16	3292	900	2023	251.0	165	20	135	330
16.1	3293	700	2000	251.0	150	16	134	240
17	3294	705	2017	247.7	150	16	135	240
18	3295	700	2050	241.3	156	15.7	136	244.92
19	3296	705	2066	236.6	160	15.7	137	251.2
20	3297	695	2099	229.6	145	15	138	217.5
21	3298	700	2148	220.5	160	15.8	142	252.8
22	3300	710	2195	210.9	155	16	146	248
23	3303	703	2254	201.1	150	16.1	150	241.5
24	3304	705	2298	193.8	150	15.8	151	237
25	3305	695	2343	186.6	150	16	156	240
26	3306	703	2385	180.1	150	15.6	159	234
27	3307	700	2429	174.0	150	16	163	240
28	3308	700	2485	166.6	144	15.4	165	221.76
29	3309	700	2525	161.8	140	15.3	169	214.2
30	3310	700	2566	156.6	138	15.4	171	212.52
31	3311	700	2605	152.2	136	15.1	173	205.36
32	3312	700	2645	147.7	130	15.2	176	197.6
33	3313	695	2682	144.0	130	14.9	179	193.7
34	3314	700	2719	140.0	132	15	181	198
35	3316	705	2757	136.3	135	14.9	184	201.15
36	3317	700	2793	132.9	134	14.9	186	199.66
37	3318	703	2829	129.5	132	14.9	188	196.68
38	3319	710	2867	126.4	130	14.7	191	191.1
39	3320	705	2903	123.6	130	14.9	194	193.7
40	3321	707	2939	120.6	132	15	196	198
41	3322	700	2974	117.8	138	14.7	198	202.86
42	3324	700	3008	115.2	129	14.7	200	189.63
43	check 0	710	1999	251.6	160	15.9	133	254.4
44	3325	690	1727		170	17.5	115	297.5

CURVE FOR SWEET SPOT TEST

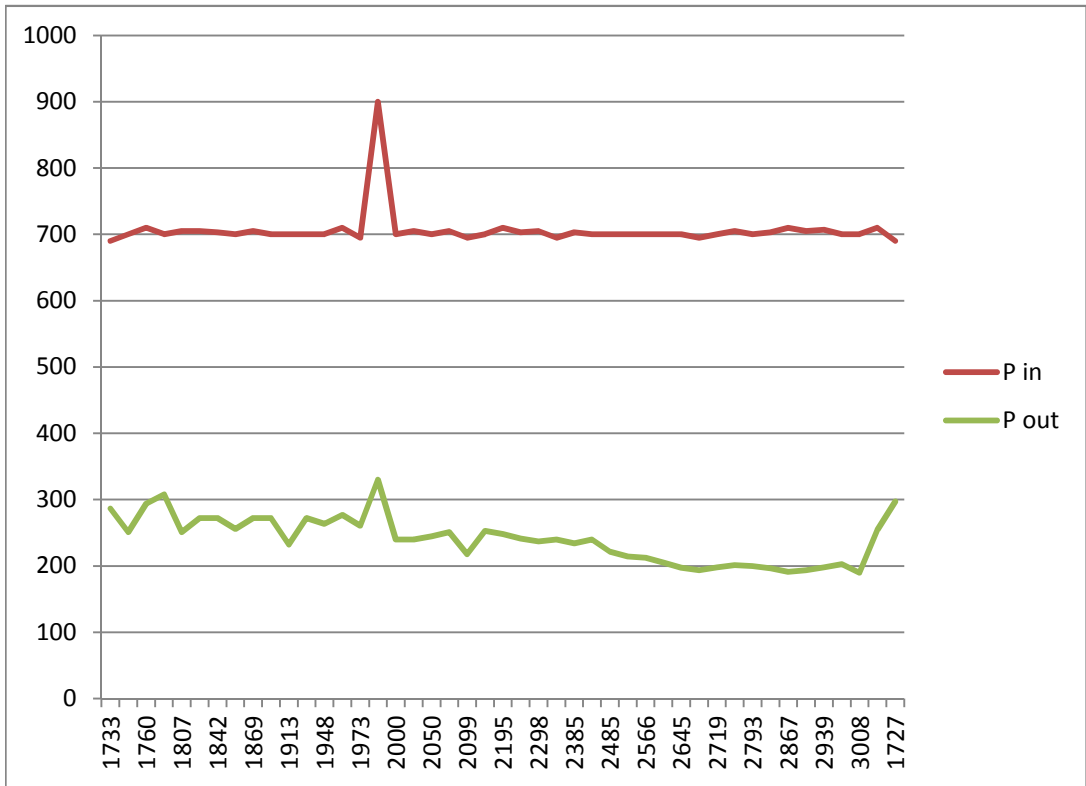

MOROCCO 2014 TEST AND MEASUREMENT NOTES

Note that Secondary resonance is double this - simply multiply by 4 instead of 2.

Witts said resonance is between 80nF and 250nF.

Problems with lower value caps arcing inside because they are in parallel, and therefore the voltage is higher across them. Therefore need to put lower voltage rating caps in series, or else just get very high voltage caps.

Tune exciter coil to 1.3MHz which is a harmonic of 432Hz which apparently was used to move stones at

Witts told Sebastien that you can put exciter coil in primary or secondary.

The 1.3MHz would seem to set up some higher vibration in core - conditioning the core over time.

Witts says the 1.3MHz arc happens for 2-3 seconds 5-6 times in an hour for the first couple of weeks, then you don't need it - implying the core has been 'conditioned' - either the 1.3MHz rides on the back of the 200/400MHz. Must go careful on output voltage on Primary - 15kV-25kV should be good enough - do not go higher as may get issues as in Taiwan. This is what spark gap across primary is used for. However, there may be ionisation and power going through spark gap without seeing / hearing it, and therefore drawing power from the load.

Therefore, need to vary spark gap distance and keep an eye on voltage across cap bank to ensure voltage does Witts says tuning is easier when grounding the secondary, but Witts said to Sebastian (German QEG) to ground primary. Sebastian said that by grounding primary he was able to double the voltage.

For cheap high voltage caps, using microwave oven caps. E.g. metal cylinder Dielektrol III 23L6240 R 0.880uF +/- 3% 2000VAC 50/60 Hz RC-QZA014WREO (See picture on camera)

QEG is high voltage, low current generator, or variable frequency generator. The voltage will always be higher on the Primary, but it can also be high on the secondary.

Exciter coil is means by which we take energy from the environment - the etheric tuning device. We set it up to 1.3MHz BEFORE it is put into circuit. So on scope there will be a mix of two frequencies 100Hz and 1.3MHz - a beat frequency - which can cause cancellation. But we think 1.3MHz will be superimposed on 100Hz (if exciter in Resonant point depends on the load - note in Load 3 data RPM and therefore LC res freq varies depending on To get over-unity, need higher voltage on the output side.

In Witts video, he uses 12 x 2000V 1.5uF caps = 125nF which is maximum with 12 1.5uF. So we know resonance To establish mechanical frequency, we tried banging with hammer and measuring with frequency spectrum analyser, but maybe not that accurate. Could use vibration tachometer and convert RPM to frequency or piezo We know that in Witts video, as he adds to load by screwing in bulbs, but he does not de-tune device. However, we have found that by adding to load (Load 3 data) it changes RPM and therefore LC resonant frequency i.e. de-tuning. Therefore, we assume he uses some electronics to manage this.

Theory - 400Hz is not the main mechanical freq, but a harmonic. Main freq would be lower - could be 200Hz.

Witts original design is to use M21 steel, which is now not available. This is interesting as this was used in 1930s, but no longer available, indicating age of design.

Witts says you can use M19, but freq would be lower (possibly, but Witts video unclear). He said you could use 200Hz instead of 400MHz and it will still work.

But, guy at Cogent Steel who had M21 data and said you can use at a particular lamination thickness at 0.025 gauge (24 gauge) which will behave as M21. This is used on QEG design.

In WITS design it says to use M21, which is not available, except specially made. He suggested using M19, but As to importance of needing exactly 400Hz mech freq - and whether it matters if you have a slightly different steel with a slightly different mech freq - we don't know. But there could be some relationship between 400Hz and Someone sent what they suspect is the circuit used by Witts in the electronics box in the video to James. See pdf. It is the 'Inverter Circuit' at position 2 in the photo/video sequence on the camera. It is the Magnetic Frequency Alternative to patent is to use AEC Grid Tied Inverter used to take up to 600V DC and turn into 50/60Hz mains voltage. This feeds back into grid if excess electricity is not used.

When in resonance, it should be difficult to increase RPM. By increasing speed on motor on variac, it deepens the resonance rather than increases RPM - sign of resonance.

Sign of resonance - sine waves on primary in phase and smooth - not double peaks.

Update - Present Stage of QEG Development, Latest Findings, & Call for Experiments

From: James Robitaille / FTW HQ, Morocco

There is some detailed engineering included in the original document released in March of 2014, but as you know, there were a few mistakes and unintentional omissions. Here is the updated manual, with corrections and much new information since the original release. We've had at least 15 groups build the machine and successfully get to the point of resonance and producing power using only that original document. All the latest information is currently being presented in the QEG 101 course (digital download). In order to keep everyone informed of the latest progress, we are posting this document here, and on the be-do website forum.

We've successfully built 5 machines ourselves, and have confirmation of reaching resonance from at least 10 other builders around the world. At the present point in development, the machine will produce a maximum of about 800 Watts output, for input of about 1,000 Watts. So we're still 200 Watts away from unity (input and output at same level).

When I say "reaching resonance", this is the 1st level (basic resonance) of 3 levels of resonance we'll need to reach before the machine will run itself, and produce usable output to power loads. The most recent work (December, 2014) was targeted at experimenting with methods to obtain the other 2 resonances, and we expect to reach that point before the end of the 10 week QEG course, ***but we need your help.***

The remaining 2 resonances involve using the core's mechanical resonant frequency to produce additional potential (voltage) through the piezoelectric effect (2nd resonance), and then using the exciter coil (which is a type of antenna) to establish the 3rd resonance which brings in further energy from the surrounding environment to 'electrify' the QEG core (this is the "quantum energy" the QEG's name refers to).

The machine was originally designed in the 1930's when modern electronics were not available, and electronics are not needed to generate output power well in excess of the input power used to run the motor and spin the rotor. Electronics are needed only for the frequency conversion (400Hz to 50/60Hz), and output voltage regulation (120/240 VAC). We have several different electronic (and some electromagnetic) solutions that can be applied once we reach that point in development, and of course we'll use the most efficient method.

When the machine is running and generating output, the primary voltage is produced by Parametric Oscillation (primary tank circuit reluctance/inductance modulated by the rotor motion). This is the source of power in the QEG, and power is transferred to the secondary windings at the zero crossing points, so there is no stall effect (very little back EMF/Lenz effect), and very little heating of the core/windings. These are some of the unique features of this generator.

Latest Findings from Experiments in Florida

The recent experiments done in Florida, USA showed some promising results. However, we had to stop working to pack up the lab and make the move here to Morocco before we could further evaluate the results. Our lab equipment has just arrived here in Morocco, but we're still setting up. So, rather than waiting for us to resume work after setting up the Morocco lab, then releasing our findings to all the groups and individuals with working QEGs (or close to that point), ***we want to ask you, the QEG builders, experimenters, and students, to try the following experiments, and help us all get to the next stages of completion.***

A technical description of the previous experiments and next steps we want to try is outlined below.

2nd RESONANCE - CORE MECHANICAL RESONANCE – A method was needed to characterize the frequency response of the wound core, in order to determine the frequency (or range of frequencies) where the core steel will 'ring' or self-resonate. This 'ringing' produces vibration which builds voltage in the core, providing an exponential increase in the power available from both the primary and secondary windings, through the piezoelectric effect. This effect is independent of (and additive to) the power produced by the basic parametric oscillation (basic resonance).

Our first attempt to find this frequency was to use a VFD (variable frequency drive) for an AC motor, driving a variac, to create a continuously variable voltage and frequency signal of 0-120VAC @ 47-450Hz. The plan was to simulate the QEG operating in resonance throughout the entire frequency range between 47-450Hz (720 to 6,750 RPM), without actually spinning the rotor, or switching resonance capacitors in and out. This continuously variable (sweep) signal was then coupled to a 9,000V neon sign transformer, with output connected to the QEG primaries (to simulate the actual QEG primary voltage) – See schematic here: <https://hopegirl2012.files.wordpress.com/2015/02/qeg-core-freq-sweep-setup.pdf> We then connected a scope across the *secondary* windings, to look for resonance peaks while manually sweeping the input (primary) frequency. The results of the test were inconclusive due to the neon sign transformer's limited output current (only 30mA). This proved to be insufficient power to drive the core. However, this led us to a modification of the test, which did prove successful.

A 600 Watt automotive audio power amplifier (with 12VDC switching power supply) was employed this time, to drive the low impedance (approx. 1.5Ω) secondaries, wired in series. We used a 20MHz signal/function generator to drive the audio amp *with a 50% duty cycle square wave signal*, between about 47Hz and 2,000Hz (2kHz). We then connected the scope across the *primary* windings (also wired in series) and observed the core's response to the input signals. The output level from the signal generator was set to about 18V, just below clipping of the signal, and the rotor was held stationary, in alignment with 2 of the pole pieces (for maximum inductance) – See schematic here:

<https://hopegirl2012.files.wordpress.com/2015/02/qeg-core-mechanical-resonance-sweep-setup.pdf>

The test was done with no load (resistance) across the primaries, in order that all aspects of the signal could be observed, including reflections and harmonics. The results provided several of the answers we've been looking for, both directly and by inference;

1. The input square wave converted to a sine wave at the output (this is a known but interesting effect when working with inductors, and is effective for determining harmonic content).

2. As we swept through the frequency range, there was a very obvious fundamental resonance just around 1,500Hz (1.5kHz). The input voltage to the secondary windings at this frequency was amplified by more than a factor of 30 at the output! We tested 2 different cores (one with epoxy impregnation, one without), and the fundamental was between 1,560Hz and 1,630Hz, depending on the rotor position. We also have one class participant that tested an unmounted bare stator (before winding) that reported reading 1,135Hz simply by tapping the steel with a small hammer. This is also close enough to confirm the test results, since the rotor, windings, spacer blocks, and mounting surfaces were not involved in the bare stator test. Because of mechanical limits, a practical maximum RPM for this machine would only be slightly over 3,000 RPM (200Hz). So we can't actually spin the rotor fast enough to output 1,500Hz directly. That would require a speed of something like 22,500 RPM. So obviously we have to run on a harmonic of 1,500Hz.

3. Carefully dialing down the frequency from 1,500Hz, we observed several harmonics that still had plenty of amplitude to excite the steel core. The first appeared around 730Hz, then 406Hz, 201Hz, and around 122Hz. The 406Hz and 201Hz harmonics are right on the frequencies Witts told us would produce the desired core steel resonance. It's important to note that the fundamental resonance appears on the scope as a huge single peak, the 1st harmonic as 2 peaks, the 2nd as 3 peaks and so on. Upon zooming out with the scope, we saw that the harmonics are actually the peaks of a 'ringing' waveform. This is a clear indication that the signal is reflecting (off the steel) at these harmonic frequencies, which is what we're after.

4. The next step is to focus on the harmonic with the most amplitude that is within the practical speed range of the generator. We are told by Witts that this should be right around 400Hz, but for the generator to run at this frequency would require RPM to be around 6,000. This is too fast for the mechanical setup. Even 3,000 RPM is a bit high, although it could be used. We know that the Witts generator we see in the "Self-Running 40kW Fuelless Generator" video is running at 2,450 RPM, which is right in the mechanical "sweet spot". With all these considerations in mind, it becomes clear that what we need to do is double the generator output frequency, but without doubling the rotor speed. ***That's where the following experiments come in.***

CALL TO OUR PROJECT SUPPORTERS TO PERFORM EXPERIMENTS - ADDITIONAL FEEDBACK COILS

To those of you who have reached resonance (or are close), we propose to add feedback coils on top of both *secondary* coils, in an experiment to transfer energy back and forth between the primary and secondary windings. With reference to Tesla's work, we would expect to see several effects realized:

1. Since the energy stored in the resonant LC tank circuit is normally supplied to the output coils (and load) during the period when the rotor is between poles (primary voltage at zero crossing), we see a path where the addition of feedback coils will serve to transfer energy (real power) back to the primary during the output interval, effectively inducing a second voltage peak halfway between the normal primary voltage peaks (remember that the output frequency is 2X the resonant tank frequency). This (50% displaced) second voltage peak would not be due to the (resonant) modulation of the primary inductance, rather it would be real power, fed back during the secondary's output cycle. We think one likely result of this modification would be a doubling of the generator frequency, without the corresponding increase in rotor speed. With some fine tuning, this should allow excitation of the core steel at the harmonic residing near 400Hz, while still running at a practical RPM.

2. The additional small wire coils (probably 20 gauge) wound over the secondaries are fairly obvious in the Witts videos. With the resonant tank capacitor value based on rotor RPM (parametric pumping frequency), and the inductance value of the primary windings, this proposed modification will effectively lengthen the wire in the primary windings (feedback coils in series with primary). This could explain why the resonance capacitors in the Witts video are apparently too few and too small to be the corresponding value for the running RPM (2,450 RPM, about 163Hz). It follows that the increase in wire length will increase inductance and therefore less capacitance would be required for the same RPM.

3. Other desirable effects will almost certainly be seen, but would be difficult to predict without actually performing the experiment. So here are the details of how we would proceed.

EXPERIMENT DETAILS:

The experiment may be easier to do on a core without epoxy since there will be more room between the secondary coils and the endplates, although it can still be done on either style to prove the concept.

- Unmount the core and remove rotor. Support the core on a strong work surface with clear space around the existing secondary windings.
- If you have a core without epoxy, we would recommend wrapping 2 layers of mica tape or Kapton tape over the existing white fiberglass outer wrap for additional insulation, since the new coils will be carrying the primary high voltage. If you have an epoxied core, no additional insulation should be necessary, although it may be easier to wind the wire if a layer of fiberglass tape is installed just so the wire won't slide around on the smooth epoxy surface.
- Using the same 20 gauge (inverter duty) wire used to wind the primaries, begin winding against the same pole piece where the existing secondary winding starts, and wind in the same direction as the secondary coils. Wind across the entire surface as evenly as possible, from pole piece to pole piece (cover entire secondary winding) - See attached schematic here: <https://hopegirl2012.files.wordpress.com/2015/02/additional-coil-setupv1.pdf>
- The optimum number of turns will have to be determined experimentally. We would start with 350 turns per winding (same as secondary number of turns), but this could be reduced (or increased) depending on how much space you have. The turns count should be the same for both coils in any case, to keep the system balanced.
- Connecting the new coils to the existing primary windings will also have to be determined experimentally. There are several possible configurations depending on phasing, bucking and non-bucking etc. We would start by connecting according to the attached schematics, which place one end of each of the new windings in series with the capacitor connected ends of each of the existing primaries, then connecting the remaining ends (of the new windings) to the resonance capacitors (extend each existing primary coil). It's also possible that the existing midpoint connection on the primaries (the 2 START leads connected together) could be opened, and the new coils inserted in series at that point. If done this way, also connect the 2 start leads of the new coils together, with END leads to START leads of existing primaries. The proper connections will become evident after testing the possible combinations – See attached

schematic here: https://hopegirl2012.files.wordpress.com/2015/02/qeg-original-setup-w-feedback_xp.pdf

CONCLUSION

Please interact with other engineers, builders, and experimenters, and let us know your results, questions, problems, observations, etc., and we will move this along!

Most Importantly, Have Fun! We're here for you.

Many Thanks and Blessings!

James & the Fix the World/QEG Team

Frequently Asked Questions Regarding the QEG

Below is a compilation of answers to the most common questions we receive.

What is the QEG Project?

How much does a QEG cost?

Where can I buy a QEG?

Is the QEG a scam (hoax)?

How much money have you spent on the QEG project?

Does the QEG work?

What is the relationship between FTW, WITTS and the QEG?

Does the QEG violate the laws of physics and why does my university instructor tell me this technology is impossible?

Why is it taking so long?

What is the specific problem that you are having to reach self running on the QEG?

Can you Answer a technical question regarding the QEG?

Where can I see your reports on the QEG project?

How can you be sure that the QEG will not be suppressed?

Will the QEG Change the world overnight?

Why is FTW in Morocco?

What is the QEG Project?

The Quantum Energy Generator (QEG) is an opensourced fueless generator prototype based on a public domain patented invention of Nikola Tesla. The type of energy that is utilized by the QEG design is different than that of a conventional generator. Once co-development is complete, the generator is designed to be highly efficient and power your home. The QEG was opensourced in March of 2014 and has been in co-development with many teams around the world since this time.

How much does a QEG cost?

The QEG is a prototype, which means it is still in development and there is not yet a fixed price for a finished product. Any skilled engineer can use the free open sourced QEG manual to source all the different components from various suppliers around the world. To help answer this question, we can provide the cost data that we have experienced through building 5 QEG's in different locations.

To build a QEG you'll need to purchase all the parts, have a workspace to build, and have a variety of mechanical tools for testing and measuring. The cost for the space and the tools may vary. A list of helpful tools has been provided in the QEG course documents.

Cost for parts:

We spent between \$6,000- \$8,000 just for the parts for each QEG we built. This does not include shipping, tools or other project expenses. We have put together an expenditures report that fully outlines all expenses of the project. We estimate that with further co-development this cost can be significantly reduced. However, we have not yet reached that industry level of development yet.

Buying a Core:

You can have a company make your core for you and wind it yourself, your costs will vary. We have a working relationship with a small company in the US called Torelco that will create a fully processed core for you and ship it. The price for a Torelco Core is \$3,095 this does not include shipping. Torelco will ship anywhere in the world.

Buying the rest of the QEG Kit:

We have a working relationship with a small company called Tesla Energy Solutions who has sourced out all the other QEG parts you'll need (does not include the core) and will send them to you in a kit. The cost for this is \$4,500, this does not include shipping. This is a convenience kit. Anyone willing to source the parts out separately on their own can do so for a lower cost. We spent between \$3,000-\$4,000 for the rest of the QEG parts, not including the core, on the QEGs that we have built. This did not include shipping. We estimate that once the project has moved forward more, this cost will be reduced, but we have not yet reached that stage in industry development.

Where can I buy a QEG?

You cannot buy a ready made QEG from a supplier yet, you will need to build one yourself or hire someone to build one for you. You can use the manual to source the parts yourself or you can purchase the core from Torelco and the rest of the Kit from Tesla Energy Solutions.

Is the QEG a scam (hoax)?

No the QEG is not a scam. The QEG is an open sourced project that is in co-development with various teams of people around the world. It is based on technology that was invented by Nikola Tesla and suppressed for 130 years. Many engineers see the electrical potential of this different form of energy production and are eager to experiment and learn. The information that the QEG provides engineers is a way to prove out energy concepts that have been purposely redacted from engineering schools by the current corporations that have a monopoly on the energy industry.

Suppression of new forms of energy production is very real and has a long dark history. Energy companies and government agencies have employed people to create websites and rumors that the QEG is a scam in an effort to control public opinion to believe that such technology is not real so that we will all keep paying our utility bills for a 600 trillion dollar industry. These statements are not just opinions, they are based in facts with mountains of evidence to support them. Please read our full report: "[What you need to know about Internet Trolls and Free Energy Debunkers](#)" for more details.

The QEG is a grassroots project that is being carried out by average people and engineers who are trying to help further the technological advancement of our human condition, and free us from the control of the energy industry.

How much money have you spent on the QEG project?

The QEG Project has been in operation since September of 2013 (18 months at the time of writing this). During this time, we have run 4 crowdfunding campaigns to raise a total of \$80,224 contributed by 1,212 people. The last QEG crowdfunding campaign was in June of 2014. In addition to funding, labor, equipment and other services were donated to the project. The value of approximately \$587,000 of professional skilled labor was donated to the project through volunteers. The value of approximately \$166,000 of professional equipment, travel accommodations and other services were donated to the project.

All funding raised through the QEG campaign was spent on the QEG project. Expenses to date for the QEG project total \$80,224. Of this, \$14,756 was spent on building the first QEG prototype, \$30,791 was spent on the public QEG build in Morocco, and \$35,126 was spent on additional QEG development and additional operations expenses related to the project over a 10 month time frame. Please see our **Public**

QEG Project Expenditures Report for the full detail of all expenditures.

Please note: We do not know of any other organization that publicly or privately discloses their expenditure reports. This is a service FTW provides to exemplify our core value of transparency in all financial interactions. We wish to pioneer this behavior for others to emulate in the new paradigm.

The QEG is the open sourced release of a new product that is in global co-development. This is a new way of releasing a product of this type that has no prior reference point. However, you can compare the total expenditures of the QEG project to the budgets of any other major electrical product development in the industry to see a stark contrast.

Here is real data from a major electric motors manufacturing company gleaned from 27 years of employment by the QEG Lead Engineer:

Under normal manufacturing circumstances:

- An annual operation budget with multiple millions of dollars at their disposal.
- A team of 20 full time paid experts to work on development.
- A pre-established supply chain that was developed over 50 years to supply all order needs.

A major corporation can take a new product from inception to market in NINE MONTHS. And this is just for something as standard as a vacuum cleaner. For something more significant, such as in the automotive industry, the same process can take 7 YEARS with triple the resources. Non-disclosure contracts are enforced by all involved and the consumer has no knowledge of the product until it is available for purchase.

The QEG circumstances:

- A Crowdfunded budget of \$80,000
- A team of three people: one developer and two assistants
- No established supply chain, but a few good leads and connections

The QEG Project Results to Date:

Over 180,000 people have downloaded the open sourced plans. Individuals in over 40 countries are in the process of developing Cottage Industry Community Units (CICU's) for local QEG production. 70 QEG prototypes (or more) are in the process of building for global co-development and research. Over 15 websites from different countries have been set up for QEG development. Many of these sights can be found on www.be-do.com.

The opensourcing of the QEG has created a global stir of QEG co-development. This includes free energy enthusiasts, engineers and physicists from all over the world, working together to troubleshoot and develop the QEG technology in a safe and open environment free from patents, controls, and other restrictions. So far, 3 stages of QEG development can be identified:

- 1) Achieving Resonance, (creating raw power)
- 2) Achieving Over Unity, (creating more energy out than it takes to run it)
- 3) Achieving Self Running, (using the energy produced to supply its own power)

FTW has built 5 QEG's in several locations: Pennsylvania USA, Taiwan, Morocco, UK, Florida USA.

FTW donated a QEG to the impoverished village of Aouchtam Morocco. A QEG build was hosted in Aouchtam and opened to the public for free. Traveling and accommodation expenses were the responsibility of those who chose to attend. 75 people representing 24 countries traveled to Aouchtam for the public QEG build. These attendees included: scientists, engineers, permaculturists, agriculturists,

astrophysicists, bloggers, radio hosts, professional singers and musicians, artists, former bank trade and finance, lawyers, former police and military, natural physicians, alchemists, professional chefs, professional authors, alternative health experts and inventors.

At the time of this report, the QEG is still in co-development and embarking on the next stage of the project which is to achieve self-running. It should be noted that generating raw power through resonance and achieving over unity is a huge breakthrough in energy technology.

Many engineers around the world are watching the FTW QEG team and sharing the results in hopes to replicate them. It is important to note that a QEG has already achieved self-running as shown in this WITTS video here: https://www.youtube.com/watch?v=-Ztt3R4Bu_0 However, instructions for how to achieve this effect of Tesla's Public Domain Design have not yet been opensourced by WITTS. FTW will publish the instructions when available and tested.

FTW has posted several updates and reports to keep the public updated on the project. A 10 week online instruction course has been offered to teach engineers around the world how to build a QEG.

Does the QEG work?

Yes the QEG works. It is a prototype that is still in development and the completion of which is not yet finished and is being researched jointly by teams around the world. In its current stage of public development, the QEG does produce power, the maximum of about 800 Watts output for 1000 Watts input. (Please note, a standard generator requires a lot more input power.) The QEG, even before its completion is extremely efficient being that it is only 200 Watts away from unity (power in equals power out). This is the stage of development for the FTW QEG project that continues to be made AVAILABLE TO THE PUBLIC.

There is a QEG that has reached a further stage of development and is shown producing 2200 Watts of power. This QEG was built by WITTS and the self-running demo can be seen in [this video here](#). The instructions for the WITTS QEG prototype are NOT AVAILABLE TO THE PUBLIC.

What is the relationship between FTW, WITTS and the QEG.

WITTS has a self-running QEG that was developed by Ronald Brandt who adapted the QEG design based on Nikola Teslas public domain patent.

James Robitaille of FTW, is an electronics engineer with 11 patents and 27 years of experience working with a major motor manufacturing company. James wanted to use his knowledge and skills to create a device that can change peoples lives in the most practical way possible; a device scaled large enough to power an entire home. Recognizing the problems with energy suppression and patent confiscation, James wanted to do something completely different; he wanted to freely give the technology to the people.

In his research to find the right device, James found the [QEG WITTS Video on Youtube](#), recognized its electrical potential to power your home, and knew that he had the skill set to make it work.

James donated \$300 (the fee at the time, it has gone up to \$1,000 since then), took 1 class (1 hour) and received a small, and incomplete amount of information about the QEG technology. The rest of the information around the open sourced QEG comes from his engineering background and his experience working with the QEG.

"I (James) have taken the WITTS class myself (1 class). Also, my host in Florida – Tesla Energy Solutions – has taken several classes. WITTS classes are not what you would expect a 'class' to be. Before a class is scheduled, a 'donation' (of minimum \$1,000.00) is required for each 1 hour skype consultation. There is no defined format or indication of how many classes would need to be taken before any "secrets" of overunity are given or discussed. They offer a tour of their lab, and a demonstration of a working overunity device for a donation of \$200,000.00. We have been trying to understand their business model for several years, but it makes no sense. Frankly, it doesn't matter to us, we are only concerned with the technology involved."

-James Robitaille

FTW has made several attempts to collaborate with WITTS in a spirit of cooperation instead of competition with no success. Currently, FTW has no relationship with WITTS, as their behavior and business model violate the **core values of the FTW organization**. Students wishing to learn about the QEG can choose to work with WITTS if they prefer their style of teaching. FTW is offering an alternative instruction course that we feel is of a higher quality at a more affordable price.

Relationship dynamics and human behaviors such as this are a part of every new energy development that is disruptive to the corporate energy industry. It is important to handle such matters efficiently wherever possible and focus primarily on the technology, which is a design based on Tesla's invention that shows the most electrical potential to power your home.

Does the QEG violate the laws of physics and why does my university instructor tell me this technology is impossible?

The QEG is an asymmetrical open system that operates according the laws of nature. It does not violate the laws of thermodynamics (physics) as these only apply to a closed symmetrical system. Asymmetrical open systems have been traditionally omitted from higher educational learning programs, so your university instructor does not know about them and assumes they don't exist.

MAXWELL, EDISON, JP MORGAN AND THE LAWS OF PHYSICS

James Clerk Maxwell FRS FRSE (1831–1879) was a Scottish mathematical physicist. His most prominent achievement was to formulate a set of equations that describe electricity, magnetism, and optics as manifestations of the same phenomenon, namely the electromagnetic field. His discoveries helped usher in the era of modern physics, laying the foundation for such fields as special relativity and quantum mechanics. In his ORIGINAL work: The Dynamical Theory of the Electromagnetic Field, Maxwell identified two separate systems, both of which were completely different from each other:

1)Asymmetrical system - an 'open' system that allows the creation of a series of exchange of energy reaction to our inputs, based on electromagnetic resonance or electromagnetic feedback in every spin (on a motor), or in every pulse of input in a static coil. One of the first asymmetrical motors was Faraday's 'Unipolar Motor,' later modified by Nikola Tesla. These systems generate their own energy and do not require fossil fuels.

2) Symmetrical system – a 'closed' system that cancels the electromagnetic resonance with every spin, which creates wasted energy in excessive heat and requires an additional energy source to run such as fossil fuels. These are the "symmetrical obsolete systems" we use every day in all of our electrical appliances.

One year after Maxwell's death in 1879, scientists Hendrick Lorentz financed by J.P. Morgan and Thomas

Edison, mutilated Maxwell's original work and spent the next two decades deleting all knowledge of asymmetrical systems that would not require the profitable oil industry to operate. They 'symmetrized' all of Maxwell's equations, and labeled these incomplete theories as the "Laws of Physics". While the laws of physics do indeed apply to symmetrical closed systems of energy, there is another set of laws: The Laws of Nature, which apply to the asymmetrical systems that have been suppressed by the financial interests of the banking families for the last 130 years.

This knowledge was banned from our educational system, and no physics or electrical engineering school on our planet would ever teach about asymmetrical systems. Instead, the first and second laws of thermodynamics, which depend on the consumption of profitable fossil fuels, would conveniently prevail in our public knowledge base.

THE FLIGHT OF THE BUMBLEBEE AND THE LAWS OF NATURE

The laws of physics tell us that perpetual motion is not possible, yet how does the earth rotate? The laws of aerodynamics tell us that bumblebees are incapable of flight, yet how do they fly?

Conventional scientists from all over the world will make statements such as: "The claim that this is going to run permanently or indefinitely doesn't seem to hold because the second law of thermodynamics tells us that this is not possible"

Around the turn-of-the-century eminent British scientist Lord Kelvin said "Radio has no future, heavier-than-air flying machines are impossible, and x-rays are a hoax" - so much for conventional science.

The laws of nature contain concepts that focus on frequency, resonance, vibration, magnetics and energy. A perfect example of this can be found in the aerodynamics-law-breaking flight of the bumblebee.

Ralph Ring is an innovative technician who worked with Otis T. Carr, a direct apprentice of Nikola Tesla. In his presentation at the Breakthrough Energy Movement Conference, Mr. Ring gives an amazing explanation of the flight of the bumblebee:

"Next to the larynx in the bumblebees throat, there is a tiny hollow tube that acts as a resonance cavity that accumulates frequency. When the bee starts beating its wings, it does this to accumulate frequency which bounces back and forth in the resonator cavity until it reaches the same frequency of the earth, known as the Schumann frequency. Once the bee reaches the same frequency as its surroundings it evens out into what is known as zero point. When anything reaches zero point you can then change the energy. The bee is now free from the gravitational influence around it, creates its own little magnetic bubble and hovers around. There are some lizards and hummingbirds that do the same thing."

This is how the laws of nature work. When you can tune something to vibrate at the same frequency as the earth and reach zero point, you are freed from the frequency influence of your environment and can then change the energy into anything you want including levitation or electrical energy.

This is how the QEG works: Teslas design causes it to resonate so that it matches the frequency of the earth, and in zero point it changes the energy into self-renewing electrical energy.

For More information and references please see [this report](#):

Why is it taking so long?

This work has no reference point, so it is extremely difficult to calculate calendar dates and deadlines. We've attempted to do this in the past, and then realized that we are working with the laws of nature, that shockingly don't like to follow corporate schedules. We will always do our best to report in real time the advances that we have made and inform everyone of what our intentions and plans are for the near future.

What is the specific problem that you are having to reach self running on the QEG?

There is no problem. This is a process of elimination and testing. For example, at the time of writing this, we have been trying to find the mechanical resonant frequency of the core, the exciter coil and the environment in order to tune all three harmonic frequencies to hit the sweet spot for overunity and self running. This is a testing trial and error process, and as ideas change and new knowledge is discovered in the lab, new experiments are done. As there is no reference point for this information most problems and experiments are discovered in a hands-on environment working with and testing the different effects that are created with the QEG.

Can you Answer a technical question regarding the QEG?

We receive many requests to answer a "quick technical question". We do not have enough time to answer these questions individually and have done our best to answer these technical questions in the be-do.com forums and on several radio show interviews. A full, in depth, step by step explanation of all technical aspects of the QEG is provided in our 10 week QEG course where we have answered most technical questions that have been presented.

Do you have any reports on the QEG project?

FTW has compiled many reports over the course of the project to keep the public informed. Each report has been posted on the HopeGirl Blog. For convenience, we are re-publishing all reports on one page of the [FTW website Here](#).

How can you be sure that the QEG will not be suppressed?

We cannot guarantee that there will be no attempt to suppress the QEG by the controlling corporations and governments. However we have implemented a strategy different than those that have been tried before us to help this break through the suppression. All other legitimate free energy devices that have been developed in the last few decades have been stopped from getting out to the public through traps such as:

- 1) Patents: the US Patent office confiscates them and forbids the inventor to invent.
- 2) Secrecy: non disclosure agreements ensure that only a handful of people know about a technology, and therefore it is easier to suppress
- 3) Greed: promises of great financial wealth are made (and usually never fulfilled) to manipulate the inventors, keep a device secret and under ownership, and therefore easy to control and suppress.
- 4) Governmental laws in "police state" countries. In some countries, the governments are attempting to make it illegal for individuals to create their own power. Laws, codes, fines and regulations around this

subject are found predominantly in the “Five Eyes Countries”: USA, UK, Canada, Australia, New Zealand.

The strategy that FTW is implementing is an attempt to thwart these common traps of suppression in an effort to get this device (and others like it) directly into the hands of the people so that it can become a new common standard of energy use. Our strategy is being implemented in the following ways:

- 1) Open source: No patents, as this device is based on a patent that is in the public domain. Therefore there is no ownership and anyone with the skills can build one without copyright infringement or patent confiscation.
- 2) Public promotion and full transparency: we do not operate under secrecy or non-disclosure agreements and all information about the device and our research is publically reported on the internet. We have used the viral nature of the internet and social media to ensure that millions of people know about the QEG and are following the progress of the project.
- 3) Crowdfunding: 1,212 people have contributed to help pay for the expenses of the QEG project. This eliminates the risk, and ability to control by any single funding entity.
- 4) Grassroots: We have implemented the QEG on a grassroots level with individuals around the world. Social media and the internet works fast, governments do not. This way people have direct access to this technology and this project which minimizes governmental interference.

The open sourcing of the QEG project done through the internet by a small family with pure intentions was an unexpected move according to the controlling powers of this world. FTW has endured a lot to protect the integrity of this project and to continue to provide information publically. To date, the QEG project has experienced suppression attempts in the following ways:

- The QEG is a targeted project for government paid trolls and “free energy de-bunkers” that protect the corporate energy industry. Please read our full report here. We have witnessed many online paid troll activities that specifically target the QEG and our family.

-We have received many online empty threats by anonymous psychopathic individuals.

- During the various QEG builds we attended, we were approached by many individuals representing various groups with ulterior motives and dark agendas. These mostly involved promises of wealth, fame and power in exchange for control of the project. Most of these individuals dissolved their relationship with the QEG (or were re-assigned to other projects) when they realized that our strategy of open sourcing, crowdfunding and co-development makes it almost impossible to buy, own or control the project.

Will the QEG Change the world overnight?

The only way to change the paradigm is slowly and gradually over a period of time. The QEG and its unique form of energy production, along with other similar devices, can and will change the paradigm of our world. The cost of energy influences the price of everything we buy. The accessibility of energy determines the freedom or control over people.

Changes of this kind do not happen overnight. They happen over a period of time, and in some cases over a period of generations.

The main goal of the QEG project is to get this technology into the hands of the people so that they can

use it to change their lives for the better and end human suffering.

Our Goal is NOT: Fame, fortune, glory, power or control.

The QEG project will continue to move forward and will succeed in its completion despite the challenges and skeptical opinions. When the QEG is self running, those that have done the work will be able to implement the updated plans. The skeptics, trolls and debunkers will continue to make claims that the QEG is a scam even while people are successfully utilizing the technology in their homes. Eventually the skeptics will give up and criticize something else, hoping the people will forget how many times the skeptics have been proven wrong. (examples: the earth is flat, human flight is not possible, the sound barrier cant be broken, etc.)

Why is FTW in Morocco?

Many businesses are leaving the US because of increasing regulations and expenses that make it nearly impossible to thrive. Considering the types of projects that FTW intends to implement around the globe, it is imperative that we do business in an environment that allows us more freedom and mobility in our business transactions. We've compared the different business climates in several locations and have chosen to set up our headquarters in Morocco for number of practical reasons:

- Morocco's Free Trade Agreements and Tax Free Zones provide an easier flow of business
- Morocco is strategically positioned to all of Europe and is considered the gateway to a growing economy in all of Africa.
- The cost of living is about 1/5 of the cost of living in the US
- Morocco encourages foreign investment and entrepreneurs to set up business in their country and provides several ways of easier access to do so
- The climate and weather are amazing!

FTW is located in the Tangier/Tetouan area of Morocco on the Mediterranean Sea.

We have been running a campaign since September of 2014 to raise funds to cover the cost of our business entity set up. See our campaign here: <https://fundrazr.com/campaigns/5sLS9/ab/5440C3?> Until we reach our goal, we are continuing to do as much of the work that we can with the resources we have.

History behind this decision:

HopeGirl first visited Morocco in 1999, fell in love with the exotic culture and way of life and always wanted to go back. During the QEG project, FTW was seeking out an ideal location to implement a true humanitarian cause of donating a QEG to a community of people in need. A small village in Morocco called Aouchtam had a population of 300 local people, 50% of them did not have electricity and many of the local women were having to pull their daily water supply out of the well. It was the perfect humanitarian environment to implement our project.

The QEG family spent 6 weeks in Morocco working on the project, during which time we were able to have hands on experience in working with Moroccan business entity formation, government and customs offices, and daily business transactions. Coming from the highly regulated business background of the US, the freedom of business movement (though not perfect) was a profound and positive contrast. We feel that we can conduct our business here in Morocco with more freedom, get more work done with fewer resources, and have a greater end result in effecting positive change.

ADDITIONAL RESOURCES

HopeGirl Blog: <https://hopegirl2012.wordpress.com>

Fix The World (FTW) Project: <http://fixtheworldproject.org>

QEG Beginner's Build Course (10 classes on 12 videos and hundreds of pages of supporting documents): <http://www.fixtheworldproject.net/qeg-individual-class-purchases.html>

Official FTW Reporting Site/Forums/CICUs: <http://be-do.com>

Ebook: How to Build an Incredibly Efficient and Potentially Fuel-less Generator: A Do-It-Yourself Guide for the Engineering Enthusiast: <http://energyefficientgenerator.com>

62 Tesla Patents: <http://www.energyefficientgenerator.com/>
video: <https://www.youtube.com/watch?v=GeP6Zws79JA>

QEG CAD drawings designed and generously donated to FTW by Ivan Rivas, 3D Senior Designer/Consultant. Email: ivanrivas012@gmail.com

Diagrams 'ORIGINAL WITTS SETUP WITH ADDITIONAL FEEDBACK COILS OVER SECONDARIES' and 'END PANELS WIRING' designed and generously donated to FTW by Tivon Rivers, Engineer. Website: <http://www.spacevisuals.com>

FTW/QEG Facebook Discussion Group:
<https://www.facebook.com/groups/FTWQEGDiscussionGroup/>



UNITED STATES PATENT OFFICE.

NIKOLA TESLA, OF NEW YORK, N. Y.

ELECTRIC GENERATOR.

SPECIFICATION forming part of Letters Patent No. 511,918, dated January 2, 1894.

Application filed August 19, 1893. Serial No. 483,562. (No model.)

To all whom it may concern:

Be it known that I, NIKOLA TESLA, a citizen of the United States, residing at New York, in the county and State of New York, have invented certain new and useful Improvements in Electric Generators, of which the following is a specification, reference being had to the drawings accompanying and forming a part of the same.

In an application of even date herewith, Serial No. 483,563, I have shown and described a form of engine invented by me, which, under the influence of an applied force such as the elastic tension of steam or a gas under pressure, yields an oscillation of constant period.

In order that my present invention may be more readily understood I will explain the conditions which are to be observed in order to secure this result.

It is a well known mechanical principle that if a spring possessing a sensible inertia be brought under tension, as by being stretched, and then freed, it will perform vibrations which are isochronous, and as to period, in the main, dependent upon the rigidity of the spring, and its own inertia or that of the system of which it may form an immediate part. This is known to be true in all cases where the force which tends to bring the spring or movable system into a given position is proportionate to the displacement.

In the construction of my engine above referred to I have followed and applied this principle, that is to say, I employ a cylinder and a piston which in any suitable manner I maintain in reciprocation by steam or gas under pressure. To the moving piston or to the cylinder, in case the latter reciprocate and the piston remain stationary, a spring is connected so as to be maintained in vibration thereby, and whatever may be the inertia of the piston or of the moving system and the rigidity of the spring relatively to each other, provided, the practical limits within which the law holds true that the forces which tend to bring the moving system to a given position are proportionate to the displacement, are not exceeded, the impulses of the power impelled piston and the natural vibrations of the spring will always correspond in direction and coincide in time. In the case of the engine referred

to, the ports are so arranged that the movement of the piston within the cylinder in either direction ceases when the force tending to impel it and the momentum which it has acquired are counterbalanced by the increasing pressure of the steam or compressed air in that end of the cylinder toward which it is moving, and as in its movement the piston has shut off at a given point, the pressure that impelled it and established the pressure that tends to return it, it is then impelled in the opposite direction, and this action is continued as long as the requisite pressure is applied. The length of the stroke will vary with the pressure, but the rate or period of reciprocation is no more dependent upon the pressure applied to drive the piston, than would be the period of oscillation of a pendulum permanently maintained in vibration, upon the force which periodically impels it, the effect of variations in such force being merely to produce corresponding variations in the length of stroke or amplitude of vibration respectively.

In practice I have found that the best results are secured by the employment of an air spring, that is, a body of confined air or gas which is compressed and rarefied by the movements of the piston, and in order to secure a spring of constant rigidity I prefer to employ a separate chamber or cylinder containing air at the normal atmospheric pressure, although it might be at any other pressure, and in which works a plunger connected with or carried by the piston rod. The main reason why no engine heretofore has been capable of producing results of this nature is that it has been customary to connect with the reciprocating parts a heavy fly-wheel or some equivalent rotary system of relatively very great inertia, or in other cases where no rotary system was employed, as in certain reciprocating engines or tools, no regard has been paid to the obtaining of the conditions essential to the end which I have in view, nor would the pressure of such conditions in said devices appear to result in any special advantage.

Such an engine as I have described affords a means for accomplishing a result heretofore unattained, the continued production of electric currents of constant period, by imparting the movements of the piston to a core or

coil in a magnetic field. It should be stated however, that in applying the engine for this purpose certain conditions are encountered which should be taken into consideration in order to satisfactorily secure the desired result. When a conductor is moved in a magnetic field and a current caused to circulate therein, the electro-magnetic reaction between it and the field, might disturb the mechanical oscillation to such an extent as to throw it out of isochronism. This, for instance, might occur when the electro-magnetic reaction is very great in comparison to the power of the engine, and there is a retardation of the current so that the electro-magnetic reaction might have an effect similar to that which would result from a variation of the tension of the spring, but if the circuit of the generator be so adjusted that the phases of the electromotive force and current coincide in time, that is to say, when the current is not retarded, then the generator driven by the engine acts merely as a frictional resistance and will not, as a rule, alter the period of the mechanical vibration, although it may vary its amplitude. This condition may be readily secured by properly proportioning the self induction and capacity of the circuit including the generator. I have, however, observed the further fact in connection with the use of such engines as a means for running a generator, that it is advantageous that the period of the engine and the natural period of electrical vibration of the generator should be the same, as in such case the best conditions for electrical resonance are established and the possibility of disturbing the period of mechanical vibrations is reduced to a minimum. I have found that even if the theoretical conditions necessary for maintaining a constant period in the engine itself are not exactly maintained, still the engine and generator combined will vibrate at a constant period. For example, if instead of using in the engine an independent cylinder and plunger, as an air spring of practically constant rigidity, I cause the piston to impinge upon air cushions at the ends of its own cylinder, although the rigidity of such cushions or springs might be considerably affected and varied by the variations of pressure within the cylinder, still by combining with such an engine a generator which has a period of its own approximately that of the engine, constant vibration may be maintained even through a considerable range of varying pressure, owing to the controlling action of the electro-magnetic system. I have even found that under certain conditions the influence of the electro-magnetic system may be made so great as to entirely control the period of the mechanical vibration within wide limits of varying pressure. This is likely to occur in those instances where the power of the engine while fully capable of maintaining a vibration once started, is not sufficient to change its rate. So, for the sake of illustration, if a pendulum is started in vibration,

and a small force applied periodically in the proper direction to maintain it in motion, this force would have no substantial control over the period of the oscillation, unless the inertia of the pendulum be small in comparison to the impelling force, and this would be true no matter through what fraction of the period the force may be applied. In the case under consideration the engine is merely an agent for maintaining the vibration once started, although it will be understood that this does not preclude the performance of useful work which would simply result in a shortening of the stroke. My invention, therefore, involves the combination of a piston free to reciprocate under the influence of steam or a gas under pressure and the movable element of an electric generator which is in direct mechanical connection with the piston, and it is more especially the object of my invention to secure from such combination electric currents of a constant period. In the attainment of this object I have found it preferable to construct the engine so that it of itself controls the period, but as I have stated before, I may so modify the elements of the combination that the electro-magnetic system may exert a partial or even complete control of the period.

In illustration of the manner in which the invention is carried out I now refer to the accompanying drawings.

Figure 1 is a central sectional view of an engine and generator embodying the invention. Fig. 2 is a modification of the same.

Referring to Fig. 1 A is the main cylinder in which works a piston B. Inlet ports C C pass through the sides of the cylinder opening at the middle portion thereof and on opposite sides. Exhaust ports D D extend through the walls of the cylinder and are formed with branches that open into the interior of the cylinder on each side of the inlet ports and on opposite sides of the cylinder. The piston B is formed with two circumferential grooves E F which communicate through openings G in the piston with the cylinder on opposite sides of said piston respectively.

The particular construction of the cylinder, the piston and the ports controlling it may be very much varied, and is not in itself material, except that in the special case now under consideration it is desirable that all the ports, and more especially the exhaust ports should be made very much larger than is usually the case so that no force due to the action of the steam or compressed air will tend to retard or affect the return of the piston in either direction. The piston B is secured to a piston rod H which works in suitable stuffing boxes in the heads of the cylinder A. This rod is prolonged on one side and extends through bearings V in a cylinder I suitably mounted or supported in line with the first, and within which is a disk or plunger J carried by the rod H. The cylinder I is without ports of any kind and is air-tight except as a

small leakage may occur through the bearings V, which experience has shown need not be fitted with any very considerable accuracy. The cylinder I is surrounded by a jacket K which leaves an open space or chamber around it. The bearings V in the cylinder I, extend through the jacket K to the outside air and the chamber between the cylinder and jacket is made steam or air-tight as by a suitable packing. The main supply pipe L for steam or compressed air leads into this chamber, and the two pipes that lead to the cylinder A run from the said chamber, oil cups M being conveniently arranged to deliver oil into the said pipes for lubricating the piston. In the particular form of engine shown, the jacket K which contains the cylinder I is provided with a flange N by which it is screwed to the end of the cylinder A. A small chamber O is thus formed which has air vents P in its sides and drip pipes Q leading out from it through which the oil which collects in it is carried off.

To explain now the operation of the engine described, in the position of the parts shown, or when the piston is at the middle point of its stroke, the plunger J is at the center of the cylinder I and the air on both sides of the same is at the normal pressure of the outside atmosphere. If a source of steam or compressed air be then connected to the inlet ports C C of the cylinder A and a movement be imparted to the piston as by a sudden blow, the latter is caused to reciprocate in a manner well understood. The movements of the piston compress and rarefy the air in the cylinder I at opposite ends of the same alternately. A forward stroke compresses the air ahead of the plunger J which acts as a spring to return it. Similarly on the back stroke the air is compressed on the opposite side of the plunger J and tends to drive it forward. The compressions of the air in the cylinder I and the consequent loss of energy due mainly to the imperfect elasticity of the air, give rise to a very considerable amount of heat. This heat I utilize by conducting the steam or compressed air to the engine cylinder through the chamber formed by the jacket surrounding the air-spring cylinder. The heat thus taken up and used to raise the temperature of the steam or air acting upon the piston is availed of to increase the efficiency of the engine. In any given engine of this kind the normal pressure will produce a stroke of determined length, and this will be increased or diminished according to the increase of pressure above or the reduction of pressure below the normal.

In constructing the apparatus proper allowance is made for a variation in the length of stroke by giving to the confining cylinder I of the air spring properly determined dimensions. The greater the pressure upon the piston, the higher the degree of compression of the air-spring, and the consequent counteracting force upon the plunger. The rate

or period of reciprocation of the piston, however, is mainly determined as described above by the rigidity of the air spring and the inertia of the moving system, and any period of oscillation within very wide limits may be secured by properly portioning these factors, as by varying the dimensions of the air chamber which is equivalent to varying the rigidity of the spring, or by adjusting the weight of the moving parts. These conditions are all readily determinable, and an engine constructed as herein described may be made to follow the principle of operation above stated and maintain a perfectly uniform period through very wide limits of pressure.

The pressure of the air confined in the cylinder when the plunger I is in its central position will always be practically that of the surrounding atmosphere, for while the cylinder is so constructed as not to permit such sudden escape of air as to sensibly impair or modify the action of the air spring there will still be a slow leakage of air into or out of it around the piston rod according to the pressure therein, so that the pressure of the air on opposite sides of the plunger will always tend to remain at that of the outside atmosphere.

To the piston rod H is secured a conductor 95 or coil of wire D' which by the movements of the piston is oscillated in the magnetic field produced by two magnets B' B' which may be permanent magnets or energized by coils C' O' connected with a source of continuous currents E'. The movement of the coil D' across the lines of force established by the magnets gives rise to alternating currents in the coil. These currents, if the period of mechanical oscillation be constant will be of constant period, and may be utilized for any purpose desired.

In the case under consideration it is assumed as a necessary condition that the inertia of the movable element of the generator and the electro-magnetic reaction which it exerts will not be of such character as to materially disturb the action of the engine.

Fig. 2 is an example of a combination in which the engine is not of itself capable of determining entirely the period of oscillation, but in which the generator contributes to this end. In this figure the engine is the same as in Fig. 1. The exterior air spring is however omitted and the air spaces at the ends of the cylinder A relied on for accomplishing the same purpose. As the pressure in these spaces is liable to variations from variations in the steam or gas used in impelling the piston they might affect the period of oscillation, and the conditions are not as stable and certain as in the case of an engine constructed as in Fig. 1. But if the natural period of vibration of the elastic system be made to approximately accord with the average period of the engine such tendencies to variation are very largely overcome and the engine will preserve its period even through a considerable range of variations of pressure. The

generator in this case is composed of a magnetic casing F' in which a laminated core G' secured to the piston rod H is caused to vibrate. Surrounding the plunger are two exciting coils C' C', and one or more induced coils D' D'. The coils C' C' are connected with a generator of continuous currents E' and are wound to produce consequent poles in the core G'. Any movement of the latter will therefore shift the lines of force through coils D' D' and produce currents therein.

In the circuit of coils D' is shown a condenser H'. It need only be said that by the use of a proper condenser the self induction of this circuit may be neutralized. Such a circuit will have a certain natural period of vibration, that is to say that when the electricity therein is disturbed in any way an electrical or electro-magnetic vibration of a certain period takes place, and as this depends upon the capacity and self induction, such period may be varied to approximately accord with the period of the engine.

In case the power of the engine be comparatively small, as when the pressure is applied through a very small fraction of the total stroke, the electrical vibration will tend to control the period, and it is clear that if the character of such vibration be not very widely different from the average period of vibration of the engine under ordinary working conditions such control may be entirely adequate to produce the desired results.

Having now described my invention, what I claim is—

1. The combination with the piston or equivalent element of an engine which is free to reciprocate under the action thereon of steam or a gas under pressure, of the moving conductor or element of an electric generator in direct mechanical connection therewith.

2. The combination with the piston or equivalent element of an engine which is free to reciprocate under the action of steam or a gas

under pressure, of the moving conductor or element of an electric generator in direct mechanical connection therewith, the engine and generator being adapted by their relative adjustment with respect to period to produce currents of constant period, as set forth.

3. The combination with an engine comprising a piston which is free to reciprocate under the action of steam or a gas under pressure, and an electric generator having inducing and induced elements one of which is capable of oscillation in the field of force, the said movable element being carried by the piston rod of the engine, as set forth.

4. The combination with an engine operated by steam or a gas under pressure and having a constant period of reciprocation, of an electric generator, the moving element of which is carried by the reciprocating part of the engine, the generator and its circuit being so related to the engine with respect to the period of electrical vibration as not to disturb the period of the engine, as set forth.

5. The combination with a cylinder and a piston reciprocated by steam or a gas under pressure of a spring maintained in vibration by the movement of the piston, and an electric generator, the movable conductor or element of which is connected with the piston, these elements being constructed and adapted in the manner set forth for producing a current of constant period.

6. The method of producing electric currents of constant period herein described which consists in imparting the oscillations of an engine to the moving element of an electric generator and regulating the period of mechanical oscillation by an adjustment of the reaction of the electric generator, as herein set forth.

NIKOLA TESLA.

Witnesses:

PARKER W. PAGE,
R. F. GAYLORD.

(No Model.)

2 Sheets—Sheet 2.

N. TESLA.
ELECTRIC GENERATOR.

No. 511,916.

Patented Jan. 2, 1894.

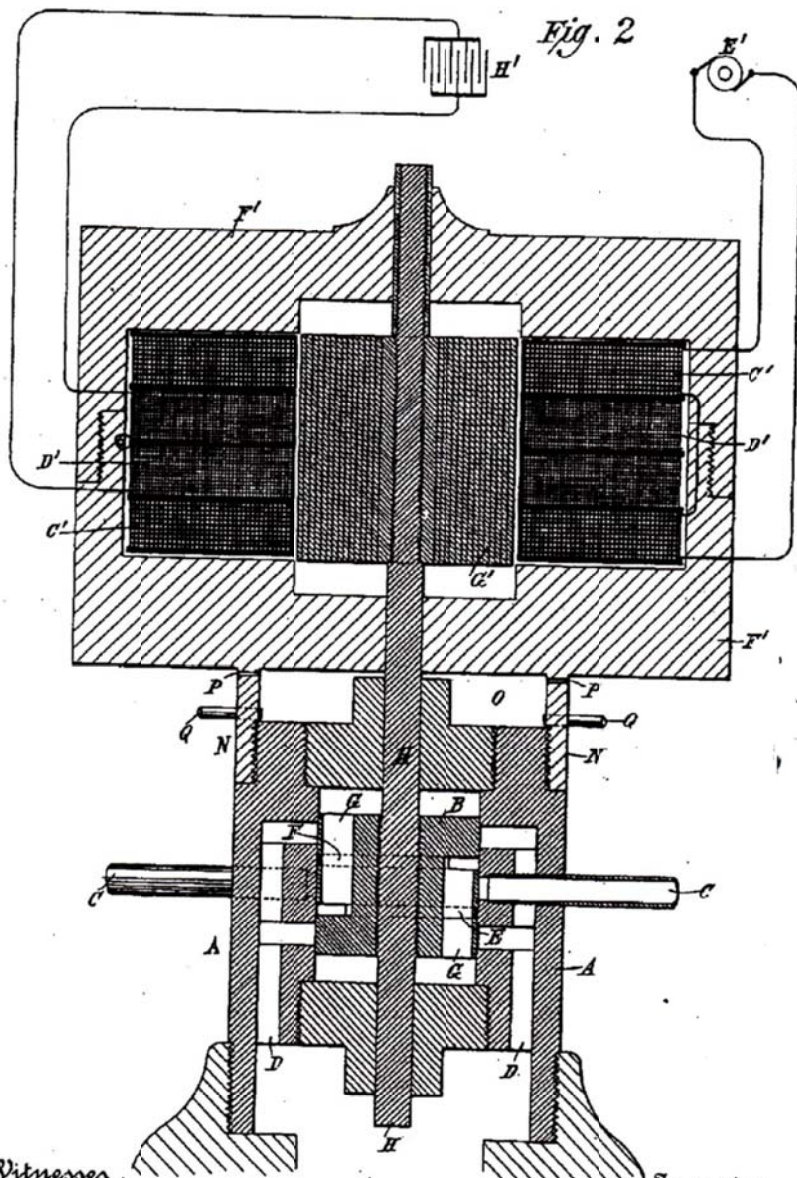

Witnesses
Raphael Netter
R. F. Gaylord

Inventor
Nikola Tesla
By his Attorneys
Duncan & Page.